

# Grindmaster Model FDD2500

## Service Manual for Model FDD2500

### Table of Contents

Warning Labels.....	2
Installation .....	3
Programming .....	4
Start-up & Adjustments .....	7
Cleaning .....	8
Shipping Preparation.....	10
Replacing Controller .....	11
Replacing Components.....	11
Product Out Adjustment.....	11
Troubleshooting Guide .....	12
Assembly Drawings .....	14
Wiring Diagrams.....	28

Prior authorization must be obtained from Grindmaster Corporation for all warranty claims.



**Model FDD2500-1-M-B**  
**Model FDD2500-3-M-B**  
**Model FDD2500-1-3A-B**  
**Model FDD2500-3-3A-B**



### Grindmaster Corporation

4003 Collins Lane  
Louisville, KY 40245 USA  
(502) 425-4776  
(800) 695-4500 (USA & Canada only)  
FAX: (502) 425-4664  
[www.grindmaster.com](http://www.grindmaster.com)

## Warning Labels

The following warning labels were on your dispenser when it was shipped from the factory. They should remain on your dispenser in good, readable condition at all times. If one of your labels is missing or damaged, order a replacement label immediately.

### Part #71582

Located on machine cover and spout mounting bracket.



### Part #63370

For FDD2500-✱M-B models only

Located on front splash panel

**RELEASE HANDLE WHEN 2/3 FULL. THIS PRODUCES A FULL CUP AND PREVENTS AN OVERFLOW.**

### Part #63371

Located next to center spout



### Part #62981

Located on front splash panel



### Part #63448

Located on tank drain hose

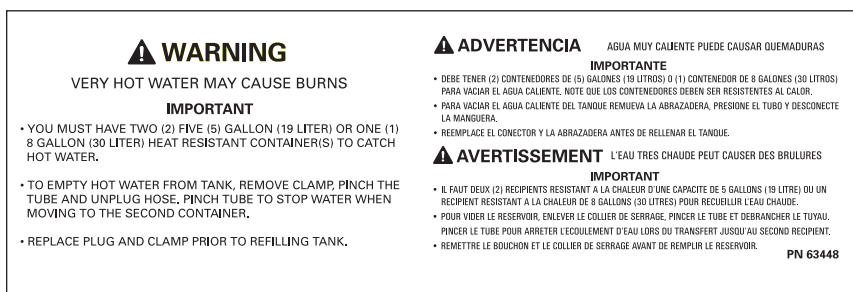

# Installation

## WATER INLET CONNECTION

The National Sanitation Foundation requires the following for an NSF approved water hook-up:

1. A quick disconnect water connection or enough coiled tubing so that the machine can be moved for cleaning underneath.
2. An approved backflow prevention device, such as a double check valve to be installed between the machine and water supply. On units plumbed to permanent water line, installation of a water filter/softener system is recommended to prevent lime and scale build up in the machine. On units pumping from remote water container, filtered water is recommended to prevent lime and scale buildup in the machine.
3. Water pipe connections and fixtures directly connected to potable water supply shall be sized, installed and maintained in accordance with Federal, State, and Local codes.

## WATER HOOK-UP

1. Install the 4" legs and hand tighten. Install the plastic drain tray onto the drain tray bracket and install drain grid. (Note: The drain tray is provided with a drill-out port to allow for plumbing to a drain.)
2. Remove front splash panel for access to water hook-up. (see Figure 1)
3. Ensure the 3/8" water supply hose has sufficient length to allow the machine to be moved for cleaning or service. Supplying hot water to the machine will greatly increase the capacity of the machine. The use of copper tubing is required to prevent rupture when using a hot water supply. A maximum inlet water temperature of 160°F (71°C) is recommended.
4. Flush the water line to purge any debris from the supply line.
5. Connect a 3/8" water line to the 3/8" male flare connection.
6. Ensure water supply to machine is within 20 to 100psi. Install a pressure regulator if pressure is too high.
7. Turn on water supply and check for leaks.

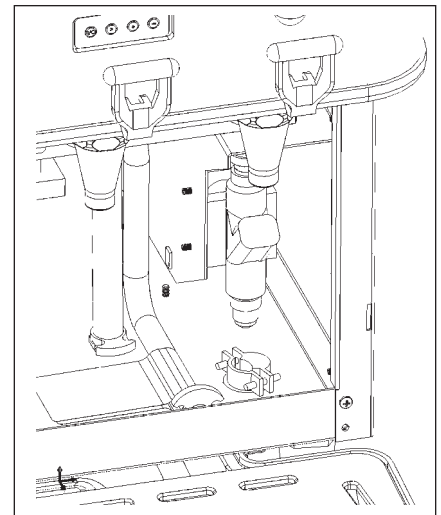

Figure 1

### **WARNING: ELECTRIC SHOCK HAZARD**

Only qualified service personnel should perform installation of this appliance. Improper installation could result in serious injury or death.

### **WARNING: ELECTRIC SHOCK HAZARD**

Never use the ground conductor as a neutral conductor. Serious injury or death could occur in the event of a fault condition.

### **WARNING: ELECTRIC SHOCK HAZARD**

Always disconnect power to the machine before servicing or cleaning. Risk of electric shock is present which can cause serious injury or death.

## Installation (cont.)

### ELECTRICAL HOOK-UP

Ensure water connection is made to machine before proceeding.

The electrical ratings for your dispenser are located on the serial plate on the outside cabinet and inside door. For configuration of three heater models to optional wattages, refer to page 31 of service manual.

1. For cord connected models, plug the power cord into an appropriate grounded and dedicated electrical outlet. Go to step 8.
2. For hard-wired models not supplied with an electrical cord, the dispenser should be connected to a dedicated circuit with a fused disconnect switch or a circuit breaker near the dispenser.
3. Strain relief is supplied under the machine chassis for power entry.  
(see Figure 2)
  - **Electrical connections and wiring materials must conform to local codes and/or be in compliance with the National Electric Code**
  - **Use only copper conductors**
4. **Note: Wiring diagram is on inside of left side panel.**
5. Connect the power supply conductors, neutral (optional) and ground wire to the appropriate positions on the terminal block. The ground lug is separate from the terminal block. Note: machine is equipped with a stepdown transformer to provide the necessary 120 volt power supply for the control circuits. Neutral will not be used.
6. Remove lid and left side panel. (see Figure 3)

**Move red wire on transformer to:**

- **“H2” for 208V supply**
- **“H3” for 240V supply**

7. Install the front splash panel.
8. Install the plastic drain tray into the drain tray rails then place drain grid onto drain tray.
9. Flip power supply to machine “ON” at the branch supply disconnect.
10. Flip power switch to the “ON” position and allow the water tank to fill. The machine will make a subtle hissing sound while filling. Allow 3-4 minutes for fill time depending on water pressure.

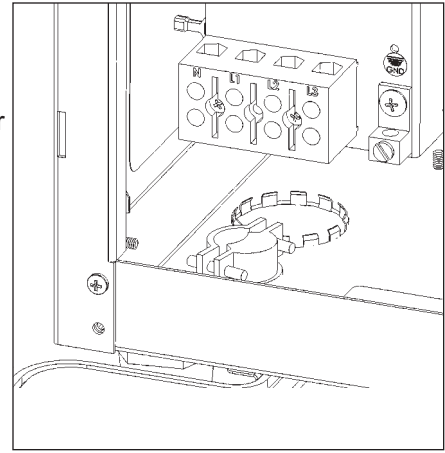

Figure 2

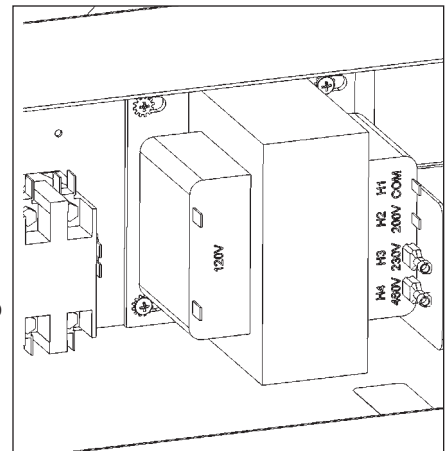

Figure 3

**Attention: This machine employs an interlock switch to disable the dispense and fill circuits when the front door is open. Ensure the front door is closed while installing or operating the machine. A watchdog circuit also monitors the water level in the tank and will disable the machine if the water level in the tank is not normal within (5) minutes of fill time. The machine will require power to be reset to clear the watchdog timeout.**

11. After the water tank has completed the fill cycle, the display will read “Water Heating” signifying that the heating element has been activated. Allow 10-45 minutes for the display to read “Ready” signifying the water tank has reached operating temperature. (Note: Heatup time is dependent on water inlet temperature and input wattage to the machine.)

# Programming Machine from Touchpads

**Tools Required:** None

**MACHINE PROGRAMMING:** The machine operating parameters can be changed from the touchpad and LCD display without opening up the machine. (See illustration below).

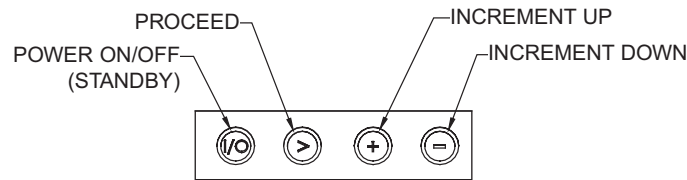

To enter **Programming Mode:**

Press and hold (>) and (+) at the same time for approximately 5 seconds.

**Tip:** Use the eraser end of two pencils to press the buttons if you are having difficulty entering programming mode.

To **Exit** programming mode at anytime:

- Wait 20 seconds without pressing a button.
- The display will prompt “Exit?”
- Press (+) or (-) to toggle between YES and NO.
- **After selecting YES, you MUST press (>) to SAVE changes**, or wait for ready message and machine will exit without saving.

**Tip:** To verify changes successfully save, re-enter programming mode and check settings.

- 1) Press (>) to select **Language. (1A)**  
Press (+) to choose English, Spanish, German, or French.
- 2) Press (>) to set the **Time** of day on the machine.  
Press (+) or (-) to change the time.
- 3) If password is activated, enter password now.
  - a) Press (+) to enter first number.
  - b) Press (>), then (+) to enter second number.
  - c) Press (>), then (+) to enter third number.

**NOTE:** The default password is “111”. If the password has been changed and forgotten, press “I/O” and “+” at the same time to proceed.

- 4) Press (>) to change **Password settings. (2B)**  
Press (+) or (-) to toggle between ON (enable password) and OFF (disable password).  
If ON is selected, press (>) to change password.
  - a) Press (>) to enter new password. (following steps 3 a, b, c)
  - b) Press (>) to confirm new password. (following steps 3 a, b, c)
- 5) Press (>) to program **Dispense Settings. (to change Portion Sizes) (2E)** (For FDD2500-\*\*-3A models only)
  - a) Press (+) for message “Select Dispense Button”. **(5A)**
  - b) Press the dispense button for the dispense head you wish to adjust the settings. LCD will display L, M, or R for left, middle, or right dispense head to acknowledge your selection.
  - c) Once the dispense head is selected, press (+) or (-) to change the amount of time (portion size) for the beverage being dispensed.
- 6) Press (>) to change **Whipper Settings. (5A1)**
  - a) Press the dispense button for the dispense head you wish to adjust the settings. LCD will display L, M, or R for left, middle, or right dispense head to acknowledge your selection.
  - b) Once the dispense head is selected, press (+) or (-) to toggle between ON (turn whipper ON) and OFF (turn whipper OFF).
- 7) Press (>) to return to **Dispense Settings. (2E)**  
Repeat steps 6 & 7 for remaining heads.
- 8) Press (>) to modify **Drink Strength. (7A)**
  - a) Press (>) to Select a Dispense Button. **(7B)**
  - b) Press the dispense button for the dispense head that you want to change the drink strength for.
  - c) Press (+) or (-) to modify the auger speed which changes the drink strength (0-100% of maximum auger speed in 1% increments).

**Note:** A faster speed will result in a stronger drink and a slower speed will result in a weaker drink.

## Programming Machine from Touchpads (cont.)

- 9) Press (>) to modify **Auger Delay**.
  - a) Press (>) and select dispense button.
  - b) Press the dispense button for the dispense head that you want to change the auger ON delay time.
  - c) Press (+) or (-) to modify the time in tenths of a second.
- 10) Press (>) to modify **Auger Off Delay**.
  - a) Press the dispense button for the dispense head that you want to change the auger OFF delay time.
  - b) Press (+) or (-) to modify the time in tenths of a second.
- 11) Press (>) to change **Heater** settings. **(8A)**  
Press (+) or (-) to toggle between ON (water tank heater ON) and OFF (water tank heater OFF).
- 12) Press (>) to modify **Water Tank Temperature**. **(7A)**  
Press (+) or (-) to increase or decrease water tank temperature.
- 13) Press (>) to modify **Low Temp/No Brew** settings. **(7B)**  
Press (+) or (-) to toggle between ON (will not allow drinks to dispense if water temperature is below programmed temperature) and OFF.
  - a) If turned ON press (>) to modify Minimum Dispensing Temp.
  - b) Press (+) or (-) to increase or decrease Minimum Dispensing Temp.
- 14) Press (>) to change **Sleep Mode** settings. **(8A)**  
Press (+) or (-) to toggle between OFF and ON (forces the water tank temperature to a programmed temperature after a programmed time of inactivity – used for energy savings).
  - a) If turned ON, press (>) to change Sleep Mode Settings.
  - b) Press (+) or (-) to increase or decrease the amount of time the unit is inactive before going into sleep mode.
  - c) Press (>) to change sleep mode water tank temperature setting.
  - d) Press (+) or (-) to increase or decrease the water tank temperature during sleep mode.
- 15) Press (>) to view **Manual Dispense** mode. **(9A)**  
(Models with manual Free-Flow Tomlinson handles cannot be changed to portion control.)
- 16) Press (>) for **Sales Mode**. **(14A)** (*This option for future use. "Free" is currently the default setting.*)
- 17) Press (>) to retrieve **Sales Data**. **(15A)**
- 18) Press (>) to view **Total Dispense** data (number of drinks dispensed per head). **(15B)**  
Press the dispense buttons that you want to retrieve information about.  
After viewing each head's data, proceed to next step.
- 19) Press (>) to view **Total Brews** data. **(15E)**  
LCD will display total number of drinks dispensed by the unit.
- 20) Press (>) for **Clear Data** options. **(16A)**  
Press (+) or (-) to toggle between YES (resets sales data counter to "0") and NO.  
**Important:** After selecting YES and then pressing (>) all data will be cleared immediately.
- 21) Press (>) to view **Dispenser Type**. **(17A)**  
LCD will display type of dispenser.
- 22) Press (>) to display **Date Code** information. **(18A)**  
LCD will display manufacture date.
- 23) Press (>) to display **Software Version** on controller. **(19A)**  
Displays current software version stored in controller memory.
- 24) Press (>) to **Retrieve Error Codes**. **(20A)**  
Press (+) or (-) to toggle through and review all error codes. The LCD will display the number of times each error code has occurred. Error Codes:  
SC1: No Water Pressure  
SC2: Reset Power (Error has occurred that requires power to be reset).  
SC3: Low Water Level (Inlet valve ON for more than 5 minutes.)

## Programming Machine from Touchpads (cont.)

24) Press (>) to **Retrieve Error Codes. (20A)** (cont.)

SC4: Thermistor Failure (Temperature is out of range – less than 32°F or greater than 210°F.)

SC6: Check Heating (Tank is too hot.)

SC8: Overcooling

SC9: Overflow (Water level safety probe is tripped.)

SC10: Adjust Temperature (Temperature adjusted from touchpad.)

25) Press (>) for **Clear Error Code** options. **(20B)**

Press (+) or (-) to toggle between YES (clears all stored error codes from memory) and NO.

**Important:** After selecting YES and then pressing (>) all data will be cleared immediately.

26) Press (>) for **EXIT** option

Press (+) or (-) to toggle between YES and NO.

**Important:** After selecting YES, you **MUST** press (>) to **SAVE** changes, or wait for READY message and machine will exit without saving.

**⚠ WARNING:** Disconnect power before servicing machine.

### FILLING PRODUCT HOPPERS (see Figure 4)

- 1) Open door.
- 2) Lift hinged top.
- 3) Remove hopper lid.
- 4) Carefully pour product into hopper.
- 5) Replace hopper lid.
- 6) Lower hinged top.
- 7) Close door.

### THERMOSTAT ADJUSTMENT

(See machine programming procedure: Water tank temperature)

**Tools required:** None

**NOTE:** The thermostat range is approximately 40°F to 205°F (4°C to 96°C). The water tank temperature is factory set at 190°F (87°C), making the beverage temperature slightly lower than 190°F (87°C).

### HOW TO DISPENSE A DRINK

Machine is equipped to dispense into cups, decanters, 1.3 L servers, 2.2 L airpots or hose connected to 5 gal. containers.

**WARNING:** Server must rest flat on tray with a 1/4" (6 mm) clearance between cup and spout. Contents can cause severe burns if handled improperly.

For Manual Machines FDD2500-1-M-B and FDD2500-3-M-B:

- 1) Place a server under the selected drink dispense nozzle.
- 2) Pull dispense handle until cup is 2/3 full, then release handle.

For Automatic Machines FDD2500-1-3A-B and FDD2500-3-3A-B:

- 1) Place a server under the selected drink dispense nozzle.
- 2) Press and release desired dispense button.

**NOTE:** To stop a dispense, simply press-and-release any button.

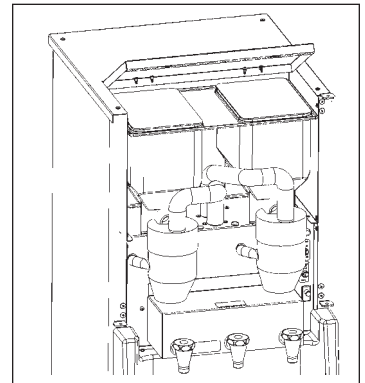

**Figure 4**

**⚠ WARNING:** Disconnect power before servicing machine.

## Cleaning

### Daily Cleaning

- 1. CAUTION:** When cleaning the unit, do not use cleansers, liquid bleach, powders or any other substance that contains chlorine. These products promote corrosion of stainless steel and plastic parts. Use of these products will void the warranty.

**⚠ WARNING:** Do not use a water jet to clean machine. Risk of electric shock.

Empty drip pan as needed and wash daily in a dish detergent.

Wipe down all surfaces of the dispense spouts, product storage cabinet, splash panel and drip tray areas with a clean soft cloth using a mixture of one ounce Ivory liquid detergent (or equivalent) to one gallon of fresh water. Follow by wiping down all surfaces of the dispense spouts, product storage cabinet, splash panel and drip tray areas with a clean soft cloth moistened with fresh water and allow to air dry.

- 2.** Rinse out the funnel by placing the rinse switch (located to the right of the dispensing valves when the door is open) in the ON position. Dispense one to two cupfuls until the water is clear. Short bursts of dispensing may also help clean the chambers. When complete, return the rinse switch to the OFF position.

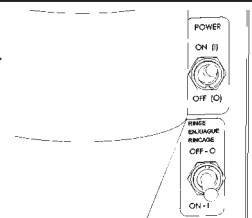

### Weekly Cleaning

#### Cleaning the Funnel – Disassembly

- 1.** Open the door and remove the large tube from the funnel cover, then remove the cover.

- 2.** Remove the mixing funnel by removing silicone tube at the side, then remove funnel.

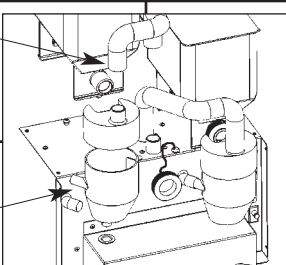











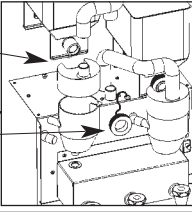

#### Cleaning the Funnel – Reassembly

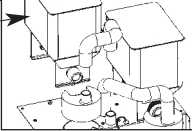
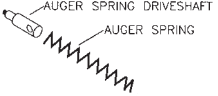
- 1.** Place funnel into position, then connect hoses.

- 2.** Place funnel cover on funnel and connect large tube.

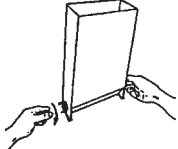
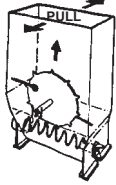
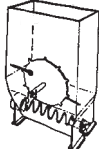
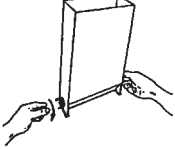
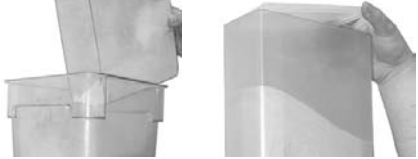
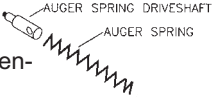
- 3.** PARTS IN CONTACT WITH FOOD MUST BE WASHED, RINSED, SANITIZED, AND AIR DRIED.

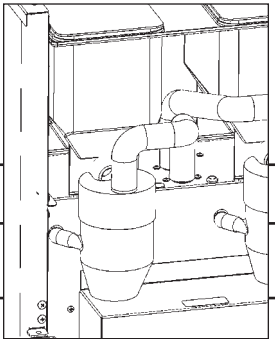
# Cleaning (cont.)

Weekly Cleaning (cont.)	
Cleaning Hoppers – Disassembly	Cleaning Hoppers – Reassembly
<p><b>⚠ CAUTION:</b> Do not wash hopper without first disassembling.</p>	<p><b>IMPORTANT:</b> All components must be completely dry prior to reassembly.</p>
<p><b>1.</b> Open door, disconnect large hose from funnel cover and then lift off funnel cover.</p> 	<p><b>1.</b> Place driveshaft bearing inside hopper with threads going through hole in the rear of the hopper.</p> 
<p><b>2.</b> Lift off ring heater and set aside.</p> 	<p><b>2.</b> Secure the bearing by attaching the palnut to the bearing outside rear hopper opening. Use one hand inside the hopper to push the bearing outward while turning the palnut clockwise.</p> 
<p><b>3.</b> Lift open lid and remove coffee spill pan.</p> 	<p><b>3.</b> Install the auger spring driveshaft and the auger spring by inserting the flat end of the spring into the</p> 
<p><b>4.</b> Remove the hopper from the cabinet.</p> 	<p><b>4.</b> Insert assembly into lower front hopper opening, making sure the threaded end of the auger spring driveshaft completely inserts into the plastic driveshaft bearing in the rear of the hopper. The driveshaft bearing threads should be accessible</p> 
<p><b>5.</b> Remove the hopper cover and empty hopper contents.</p> 	<p><b>5.</b> Place the washer over the driveshaft bearing threads followed by securing the drivelinek onto the driveshaft bearing by turning counterclockwise. Secure the auger spring with one hand while attaching the drivelinek with the other.</p> 
<p><b>6.</b> Remove the auger pinwheel by pulling it forward while stretching out the sides of the hopper.</p> 	<p><b>6.</b> Replace the auger pinwheel making sure the pins are securely positioned inside the locator holes in the hopper.</p> 
<p><b>7.</b> Remove the drivelinek and washer at the rear of the hopper by holding the auger spring with one hand at the front of the hopper while turning the drivelinek clockwise with the other hand.</p> 	<p><b>7.</b> Carefully fill the hopper with product and replace the cover.</p> 
<p><b>8.</b> Remove the auger spring and auger spring driveshaft by pulling out through the lower front opening of the hopper.</p>  	<p><b>8.</b> Reinstall hopper into the machine, making sure it is properly aligned.</p> 
<p><b>9.</b> Remove the palnut at the rear of the hopper by turning it counterclockwise then remove the driveshaft bearing from the inside of the hopper.</p>  	<p><b>9.</b> Install ring heater to front spout.</p>
<p><b>10.</b> All parts in contact with food must be washed, rinsed, sanitized, and air dried.</p>	<p><b>10.</b> Open lid and install coffee spill pan.</p> <p>Install funnel cover with large tube attached.</p>

## Prepare for Shipment





**Important:** Always completely empty water tank and **PRODUCT HOPPERS** prior to shipping unit. (See Draining the Tank and Cleaning the Hoppers section).

**NEVER SHIP UNIT WITH PRODUCT IN HOPPER OR WATER IN TANK – THIS WILL CAUSE IRREPARABLE DAMAGE.**

## Draining the Tank

Always empty the tank before shipping.

**⚠ WARNING:** Draining of the tank should be performed by a qualified service technician. The tank contains 7.5 gallons (28.4L) of very hot water. May cause severe burns.

<p><b>1.</b> Prepare a heat resistant container to drain 7.5 gallons (28.4L) of hot water from the tank into.</p>	<p><b>5.</b> Pinch hose with fingers and remove the hose clamp and plug.</p>	
<p><b>2.</b> Disconnect power to machine.</p>	<p><b>6.</b> Allow the tank to drain completely.</p> <p><b>NOTE:</b> It may be necessary to pinch the hose and stop the water before container is full. Carefully re-install plug, then empty container. Repeat steps 4-6 to completely drain tank.</p>	
<p><b>3.</b> Remove the drain tray and front access panel.</p>	<p><b>7.</b> Once the tank is empty, securely replace the plug and clamp on the end of the hose. Reposition the drain hose.</p>	
<p><b>4.</b> Locate the silicone drain hose. Put the end of the drain hose into the container. Secure the end of the drain hose (i.e. with tape) into the container.</p>	<p><b>8.</b> Reassemble the front access panel and drain tray.</p>	

**⚠ WARNING:** Disconnect power before servicing machine.

## REPLACING CONTROLLER

**Tools Required:** Phillips Head Screwdriver

1. Remove 4 screws and lift off lid.
2. Lift off right side panel.
3. Carefully disconnect each wiring connector from controller.

**NOTE:** Pull only on connectors. Do not pull on wires.

4. Carefully spring-back mounting clips and lift controller out of clips.

**NOTE:** Do not pull or press on sensitive controller components. Handle controller by touching the edges.

**NOTE:** Reverse procedure to install controller. Make sure connector ramps and pins are properly aligned before installing connectors.

## REPLACING COMPONENTS

**Tools Required:** Phillips Head Screwdriver

1. Remove drain tray.
2. Remove 2 screws then remove front panel.
3. Remove 4 screws then remove lid.
4. Lift off side panels and/or rear panel.
5. Replace components as needed.

## ADJUSTMENT TO "ADD PRODUCT" SENSORS

Capacitive Sensors might need to be adjusted if either situation occurs:

- Hoppers are full and display reads "ADD PRODUCT" when attempting a dispense.
- Hoppers are empty and display does NOT read "ADD PRODUCT" when attempting a dispense.

### Adjusting Capacitive Sensors:

1. Remove both hoppers.
2. Remove Sensor screws and gently pull sensor into cabinet. (see Figure 5)
3. Fill one hopper half full with product.
4. Hold sensor ("bulls-eye" side) flat against the full half of the hopper. (see Figure 6)
  - \* Indicator light should be "ON"
5. Slowly move sensor away from the full half of the hopper.
  - \* Indicator light should turn "OFF" 1/16" from hopper. (see Figure 7)
  - \* If needed, adjust sensor with micro-screwdriver by gently turning adjustment screw. (see Figure 8)
6. Hold sensor ("bulls-eye" side) flat against the empty half of the hopper. (see Figure 6)
  - \* Indicator light should be "OFF"
  - \* If indicator light is "ON", adjust sensor with micro-screwdriver until light turns "OFF".
7. Repeat steps 4 through 6 until no adjustment is needed.

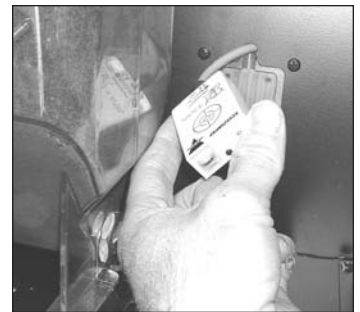

Figure 5

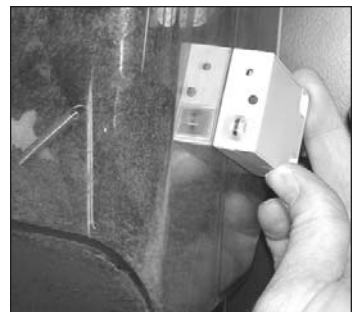

Figure 6



Figure 7



Figure 8

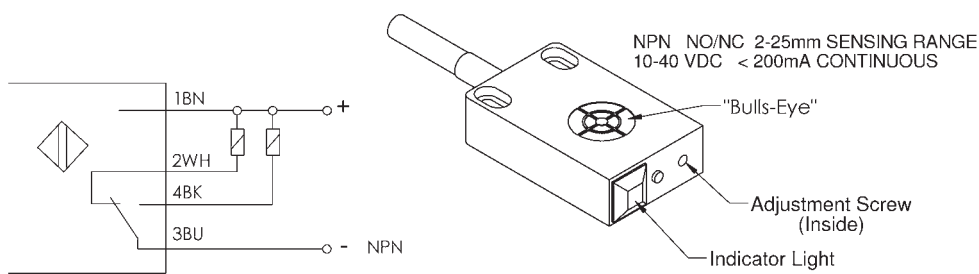

Capacitive sensors detect materials due to their dielectric constant. The bigger the material size, the higher the density of material, the higher the likeliness of detecting the material.

# Troubleshooting Guide

NOTE: The LCD display provides diagnostic feedback for determining the cause of fault or abnormal conditions. Error codes listed below are stored in the controller memory and can be retrieved through the programming menu. Additional diagnostic LEDs are located on the controller located behind the right side panel. See wiring schematics for LED locations and descriptions. Disconnect power before servicing machine. Failure to do so can result in risk of electric shock.

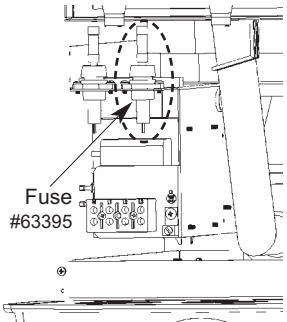
Problem	Possible Cause	Solution
LCD display not illuminated	<ul style="list-style-type: none"> <li>Power switch turned "OFF"</li> <li>No power supplied to machine</li> <li>Ground Fault Circuit Interrupter (GFCI) has tripped</li> <li>Machine control transformer circuit breaker has tripped</li> <li>Fuse has blown.</li> <li>Faulty wiring connections</li> </ul>	<ul style="list-style-type: none"> <li>Press and release "I/O" button located under the display.</li> <li>Turn power switch "ON".</li> <li>Ensure machine is plugged in at wall socket.</li> <li>Reset GFCI (if applicable) at power outlet</li> <li>Check if green LED is illuminated on control board located behind right panel. If LED is not illuminated, reset the control transformer circuit breaker located next to the control board.</li> <li>NOTE: An overload condition can reoccur. The overload condition must be diagnosed and corrected.</li> <li>Replace fuse. (see figure on right)</li> <li>Ensure all wiring connectors are plugged into display board and control board correctly. Check if any wires have pulled loose from terminals.</li> </ul> 
<b>LCD display shows error code (i.e. SC 1, 2, 3, etc.)</b>		
SC1: No Water Pressure	<i>This feature is disabled and should not appear.</i>	
SC2: Reset Power	<ul style="list-style-type: none"> <li>A fault condition described below has occurred requiring power to be reset to machine.               <ol style="list-style-type: none"> <li>Water tank fill circuit has exceeded the maximum run time (5 minutes)</li> <li>A water tank overflow condition has occurred</li> <li>A water tank heating condition has exceeded the water tank temperature set point due to:                   <ul style="list-style-type: none"> <li>Welded contacts on heater contactor</li> </ul> </li> </ol> </li> </ul>	<ul style="list-style-type: none"> <li>For #1-3, turn power switch OFF for 5 seconds, then ON.</li> <li>Call Technical Service for assistance.</li> </ul>
SC3: Low Water Level	<ul style="list-style-type: none"> <li>Machine is filling the water tank</li> <li>Faulty water inlet valve electrical connections</li> <li>Faulty water inlet valve</li> <li>Insufficient water flow rate to machine (typically during dispensing only).</li> </ul>	<ul style="list-style-type: none"> <li>Allow machine to fill the water tank</li> <li>Ensure electrical leads are properly made to water inlet valve</li> <li>Check for power across water inlet valve terminals. If power is not detected, replace water inlet valve.</li> <li>Allow water tank to fill. If problem continues, check for restrictions in water line and check for proper water pressure (20-100 psi).</li> </ul>
SC4: Thermistor Fail	<ul style="list-style-type: none"> <li>Thermistor is disconnected</li> <li>Thermistor was subjected to sudden temperature change (i.e. filling or draining tank)</li> <li>Thermistor resistance valve is out of "valid" range</li> </ul>	<ul style="list-style-type: none"> <li>Check thermistor wiring connections</li> <li>Allow water temperature to stabilize, reset power to machine.</li> <li>Reset power first, if continues, check thermistor resistance (consult factory for details), replace if necessary</li> </ul>
SC6: Check Heating	<p>Water temperature has increased above set point due to:</p> <ul style="list-style-type: none"> <li>Abnormal increase or decrease in water tank temperature</li> <li>Welded contacts on heater contactor.</li> </ul>	<ul style="list-style-type: none"> <li>Inlet water temperature must be below temperature set point of water tank</li> <li>Check heater contactor for welded contacts, replace contactor if necessary</li> </ul>
SC9: Overflow condition	<ul style="list-style-type: none"> <li>Water inlet valve weeping (leaking valve seal)</li> <li>Water inlet valve stuck open</li> <li>Loose water level probe connection</li> </ul>	<ul style="list-style-type: none"> <li>Replace inlet valve</li> <li>Replace inlet valve</li> <li>Check connection to water level probe</li> </ul>
Add Product	<ul style="list-style-type: none"> <li>Hopper is empty</li> <li>Hopper is disengaged</li> <li>Capacitive sensor needs to be adjusted</li> </ul>	<ul style="list-style-type: none"> <li>Fill hopper</li> <li>Make sure hopper is properly in place</li> <li>See "Add Product" Adjustment section on page 9.</li> </ul>

## Troubleshooting Guide (cont.)

Problem	Possible Cause	Solution
LCD display shows "Standby"	<ul style="list-style-type: none"> <li>Machine is in "STANDBY" mode</li> </ul>	<ul style="list-style-type: none"> <li>Press "I/O" on touchpad to activate machine. (Standby switch acts as a power switch to the control module of the machine; however, the machine is still powered up.)</li> </ul>
No water or product is dispensed	<ul style="list-style-type: none"> <li>Machine is in "STANDBY" mode</li> <li>Door is open</li> </ul>	<ul style="list-style-type: none"> <li>Press "I/O" on touchpad to activate machine. (Standby switch acts as a power switch to the control module of the machine; however, the machine is still powered up.)</li> <li>A door interlock disables the dispense circuit when the door is open. The door interlock switch is located behind the door near the lower hinge and can be overridden by pulling the switch plunger out. The switch will reset when the door is closed.</li> </ul>
No water is dispensed	<ul style="list-style-type: none"> <li>Blockage in water delivery circuit</li> </ul>	<ul style="list-style-type: none"> <li>Check for kinked water delivery tubing, lime and scale blockage to and from dump valve.</li> </ul>
Powder not dispensing	<ul style="list-style-type: none"> <li>Coffee dispense outlet clogged</li> <li>Hopper drive link not engaged with drive motor</li> <li>Low or no product</li> <li>"Drink Strength" setting too low</li> </ul>	<ul style="list-style-type: none"> <li>Clean hoppers according to cleaning procedure</li> <li>Remove and reinstall hopper to engage with drive motor</li> <li>Check product container for product</li> <li>Check "Drink Strength" setting (see programming guide for setting Drink Strength)</li> </ul>
Water overflows mixing funnel	<ul style="list-style-type: none"> <li>Powder flow rate too fast – too much powder to water ratio can prevent adequate mixing resulting in blockage in mixing funnel</li> <li>Outlet is restricted</li> </ul>	<ul style="list-style-type: none"> <li>Adjust powder flow rate to prevent blockage in mixing funnel</li> <li>Ensure mixing chamber outlets are free of blockage. Follow rinse and cleaning procedure to prevent buildup of product in mixing system.</li> </ul>
Drink is too cold or hot		<ul style="list-style-type: none"> <li>Check temperature set point and adjust as needed. (Refer to Programming Guide for Thermostat Adjustment section)</li> </ul>
Drink is too weak or strong		<ul style="list-style-type: none"> <li>Check drink strength to desired taste. (Refer to Programming Guide for Drink Strength Adjustment)</li> </ul>
Water tanks boils water	<ul style="list-style-type: none"> <li>Water temperature too high for elevation of installation</li> </ul>	<ul style="list-style-type: none"> <li>Adjust water temperature down. Refer to Thermostat Adjustment section.</li> </ul>

**If you still need help, call our service department (Monday – Friday, 8 am – 6 pm EST) at (800) 695-4500 (USA and Canada only) or (502) 425-4776 or an authorized service center in your area. Please have the model and serial numbers ready so that accurate information may be given. Prior authorization must be obtained from Grindmaster Corporation's Technical Services Department for all warranty claims.**

# FDD2500 Assembly

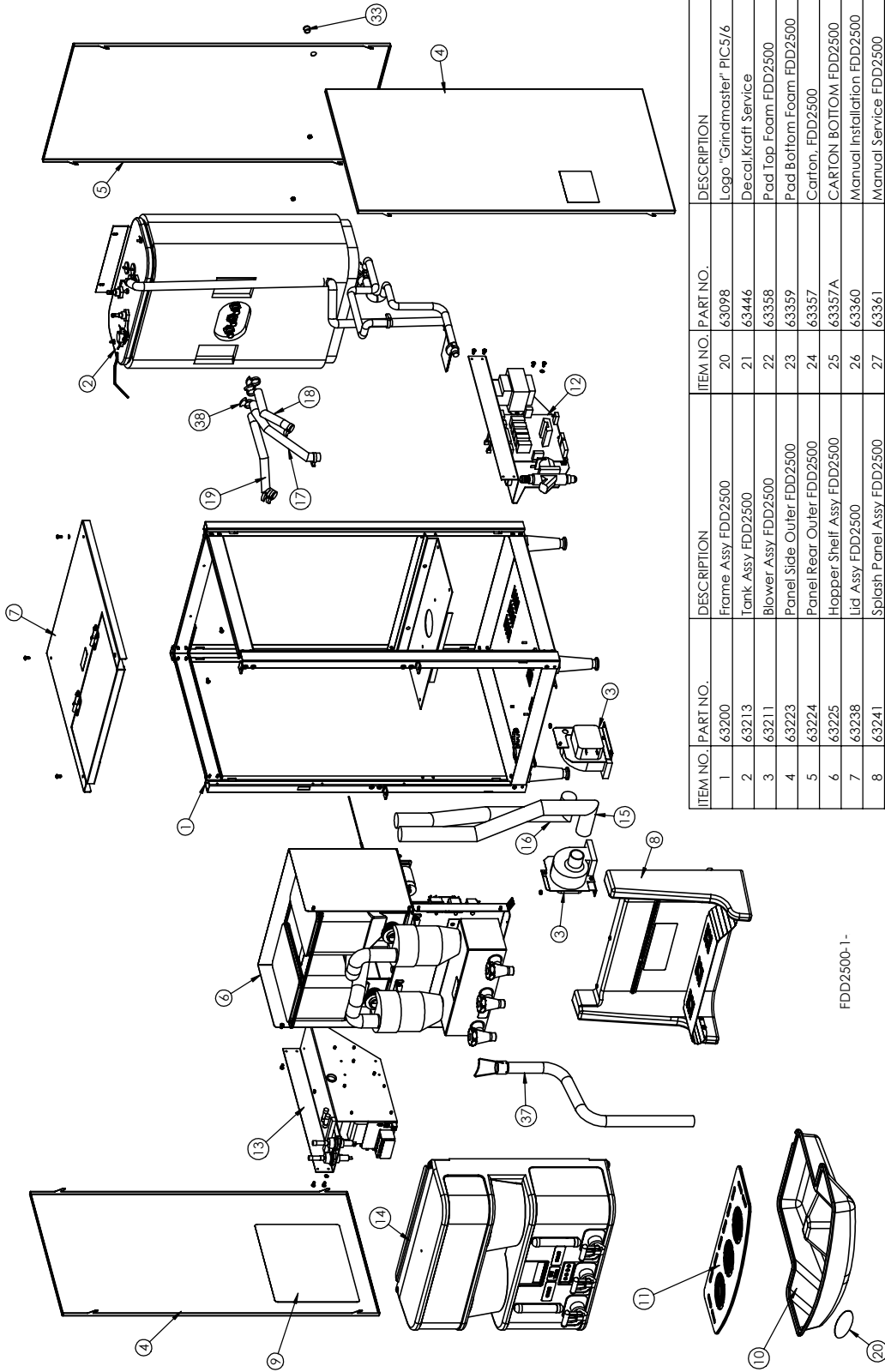

ITEM NO.	PART NO.	DESCRIPTION	ITEM NO.	PART NO.	DESCRIPTION
1	63200	Frame Assy FDD2500	20	63098	Logo "Grindmaster" PIC5/6
2	63213	Tank Assy FDD2500	21	63446	Decal Kraft Service
3	63211	Blower Assy FDD2500	22	63358	Pad Top Foam FDD2500
4	63223	Panel Side Outer FDD2500	23	63359	Pad Bottom Foam FDD2500
5	63224	Panel Rear Outer FDD2500	24	63357	Carton, FDD2500
6	63225	Hopper Shell Assy FDD2500	25	63357A	CARTON BOTTOM FDD2500
7	63238	Lid Assy FDD2500	26	63360	Manual Installation FDD2500
8	63241	Splash Panel Assy FDD2500	27	63361	Manual Service FDD2500
9	63388	Decal Wiring Configs FDD	28	100736	Decal Flavor Strip Kraft Soluble
10	63245	Tray, Drain FDD2500	29	63451	Card Cleaning FDD2500
11	63246	Grid Drain FDD2500	30	63450	Sheet Installation Check FDD2500
12	63293	Control Brkt Assy FDD2500 Rt	31	63427	Decal CDE for Box
13	63249	Contactor Brkt Assy FDD2500	32	92716	Warning Card Assy
14	63331	Door Assy FDD2500	33	61157	PLUG, HOLE 1/2 HEYCO #3065
15	61123-FDD-Left	Hose 1-1/4 ID, 24"	34	71129	NUT, 8-32 KEPS SS
16	61123-FDD-Right	Hose 1-1/4 ID, 24"	35	61303	Screw, #8 x 3/8 black trilobe
17	62271 FDD Md Re	Tube Silicone 1/2 x 3/4 X 8.75"	36	61186	Washer, #8 Int Lock
18	62271 FDD Rt Re	Tube Silicone 1/2 x 3/4 X 6"	37	63402	Hose Adapter Assy FDD2500
19	62271 FDD Lt Re	Tube Silicone 1/2 x 3/4 X 8.75"	38	71676	Clamp .671-.812 Nylon Hose

FDD2500-1-

# FDD2500 Frame Assembly

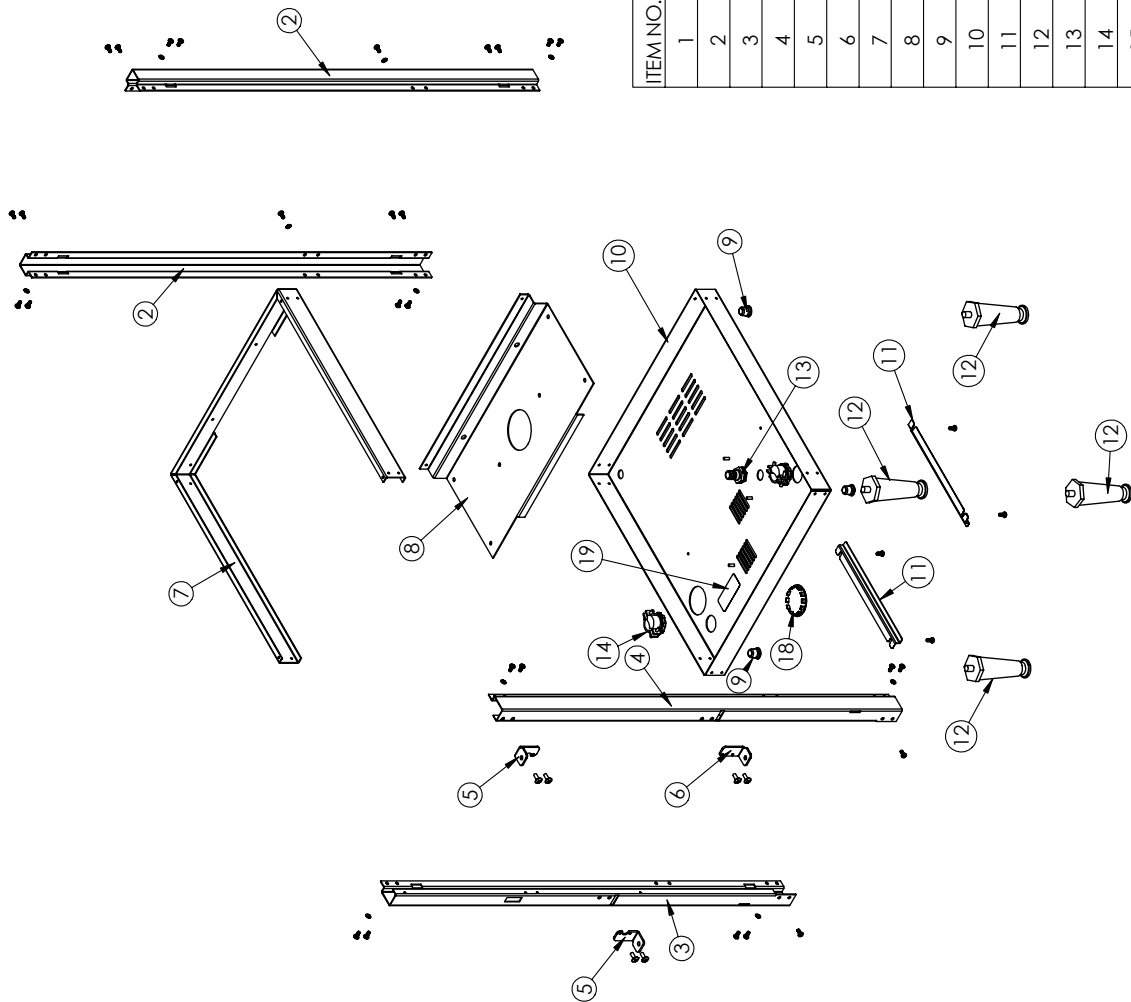

ITEM NO.	PART NO.	DESCRIPTION
1	63201	Shell Drawing for FDD2500
2	63202	Bracket Rear Corners FDD2500
3	63203	Bracket Front Left Corner FDD2500
4	63204	Bracket Front Right Corner FDD2500
5	63205	Bracket Hinge Top FDD2500
6	63206	Bracket Hinge Bottom FDD2500
7	63207	Bracket Upper Brace FDD2500
8	63208	Bracket Tank Cradle FDD2500
9	60380	RIVNUT, 3/8-16
10	63210	Panel Base Pan FDD2500
11	63119	Rail, Drain Tray PIC5/6
12	71256	Leg, 4" Plastic
13	62269	Fitting, 1/2" Barb SS
14	07920	Connector, 3/4 Conduit Metal Romex
15	61303	Screw, #8 x 3/8 black trilobe
16	61236	SCRW, 10-32X1/2 PH TR SS
17	61186	Washer, #8 Int Lock
18	63397	Plug, Hole, 1.75" Metal
19	63389	Decal, Field Wiring FDD

# FDD2500 Door Assembly

for models FDD2500-1-M-B  
FDD2500-3-M-B

ITEM NO.	PART NO.	DESCRIPTION	ITEM NO.	PART NO.	DESCRIPTION
1	63332	Door Outer Plastic FDD2500	20	63384	Screw 1/4-20 x 1 SS Ph Hd
2	63253	Door Weldment FDD2500	21	61303	Screw #8 x 3/8 black trilobe
3	63401	Display,LCD FDD2500	22	63296	Harness Display-Switches FDD2500
4	100117	Support,Circuit Board	23	W0611073	1/4-20 Nylon Lock-nut
5	63255	Panel,Access Rear Door FDD2500	24	71129	NUT, 8-32 KEPS SS
6	100050-FDD	Harness Cable Door FDD2500	25	61334	Washer, Slinger
7	100068	Strain Relief,Heyco,SR5M-3	26	63282	Switch Assy FDD
8	63281	Bracket,Display Mtg FDD2500	27	63283	Switch Assy FDD
9	62841	Touchpad, Adj only FDD	28	63284	Switch Assy FDD
10	63258	Cover,Display Plastic FDD2500	29	100736-C	Label COFFEE (part of 100736)
11	63286	Decal,Display Cover FDD2500	30	63443	Label HOT WATER FDD
12	62219	Spacer, Key Lock	31	100736-D	Label DECAF (part of 100736)
13	100115	Latch,Thumb			
14	62556	Cam,Straight,Hook,0.883			
15	63289	Sight Gage Assy FDD2500			
16	63287	Decal,Shuttles FDD2500			
17	63292	Decal Upper Door FDD2500			
18	63288	Decal Brew Basket FDD2500			
19	63298	Screw 1/4-20 x 1/2 SS Ph Hd			

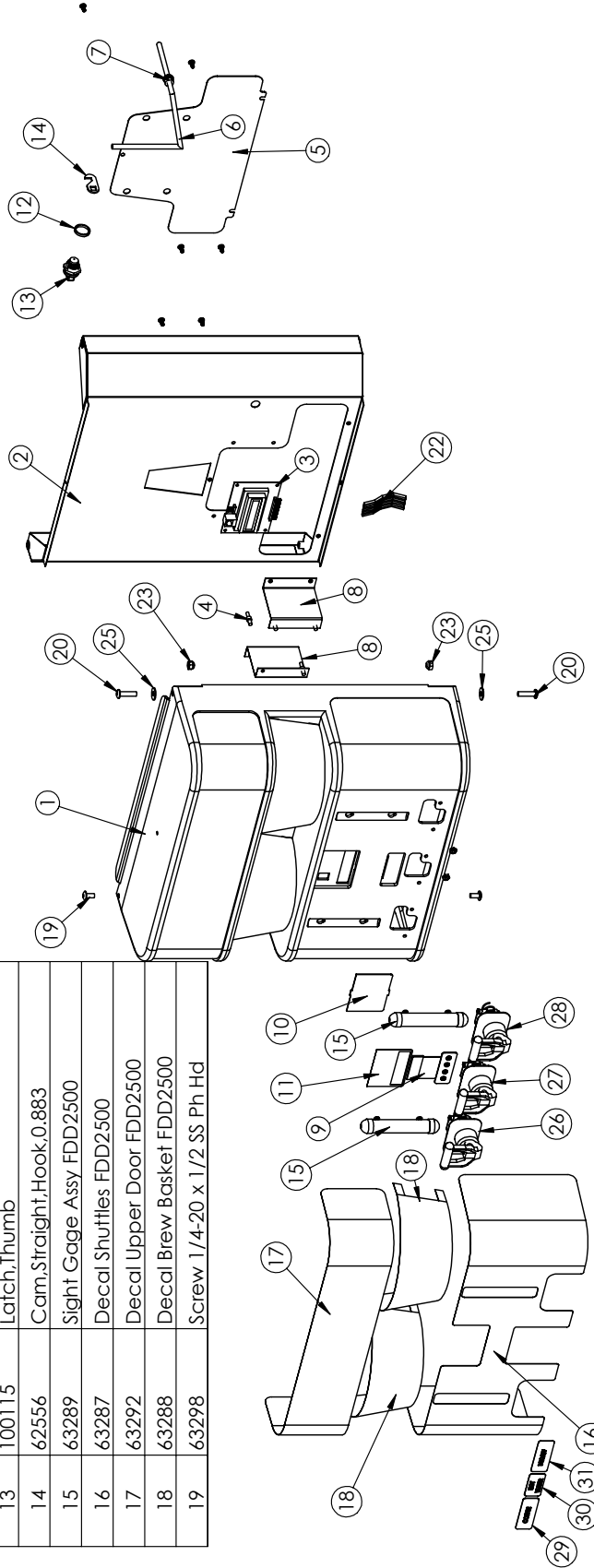

# FDD2500 Door Assembly

for models FDD2500-1-3A-B  
FDD2500-3-3A-B

ITEM NO.	PART NO.	DESCRIPTION	ITEM NO.	PART NO.	DESCRIPTION
1	63332	Door Outer Plastic FDD2500	19	63298	Screw 1/4-20 x 1/2 SS Ph Hd
2	63253	Door Weldment FDD2500	20	63384	Screw 1/4-20 x 1 SS Ph Hd
3	63401	Display,LCD FDD2500	21	61303	Screw, #8 x 3/8 black trilobe
4	100117	Support,Circuit Board	22	63438	Harness Switch 3-Port FDD2500
5	63255	Panel Access Rear Door FDD2500	23	W0611073	1/4-20 Nylon Lock-nut
6	100050-FDD	Harness Cable Door FDD2500	24	71129	NIUT, 8-32 KEPS SS
7	100068	Strain Relief,Heyco,SR5M-3	25	61334	Washer, Slinger
8	63281	Bracket Display Mtg FDD2500	26	63435	Touchpad Assy 3-Port FDD2500
9	62841	Touchpad, Adj only FDD	27	63283	Switch Assy FDD
10	63258	Cover Display Plastic FDD2500	28	100736-C	Label COFFEE (part of 100736)
11	63286	Decal Display Cover FDD2500	29	63443	Label HOT WATER FDD
12	62219	Spacer, Key Lock	30	100736-D	Label DECAF (part of 100736)
13	100115	Latch,Thumb	31	63452	Decal, Cleaning Door FDD
14	62556	Cam,Straight,Hook,0.883			
15	63289	Sight Gage Assy FDD2500			
16	63287	Decal Shuttles FDD2500			
17	63292	Decal Upper Door FDD2500			
18	63288	Decal Brew Basket FDD2500			

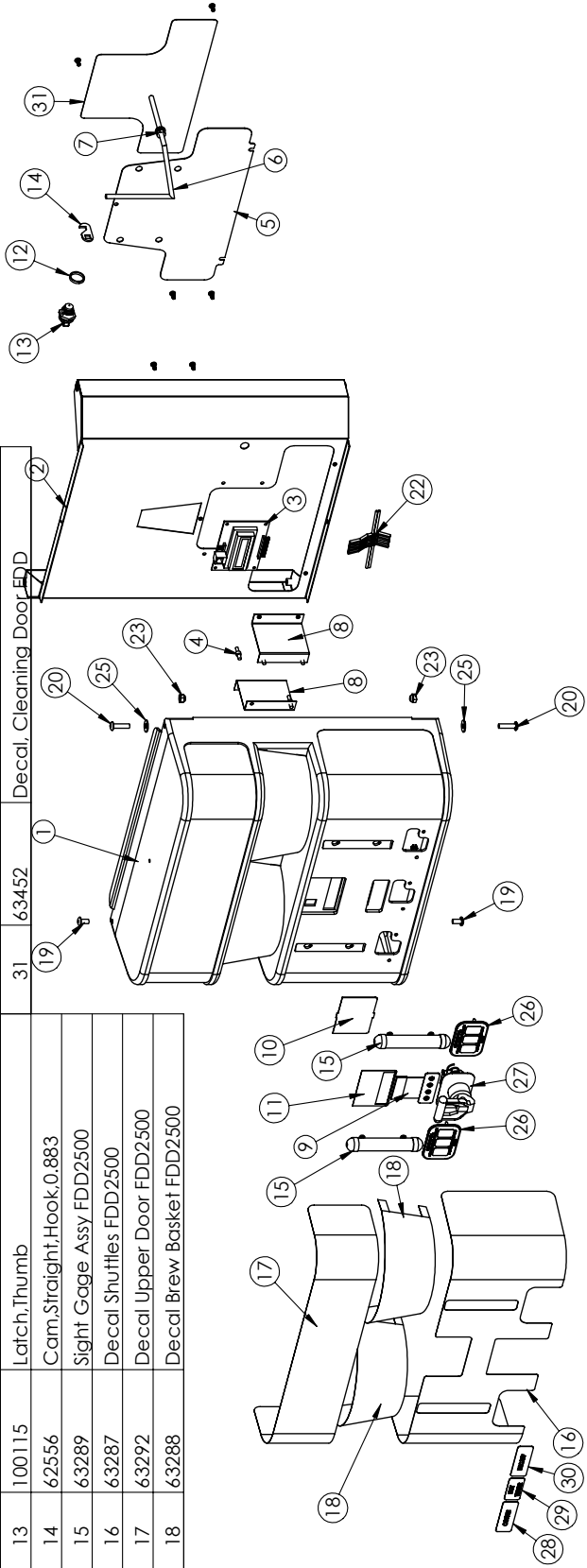

## FDD2500 Lid Assembly

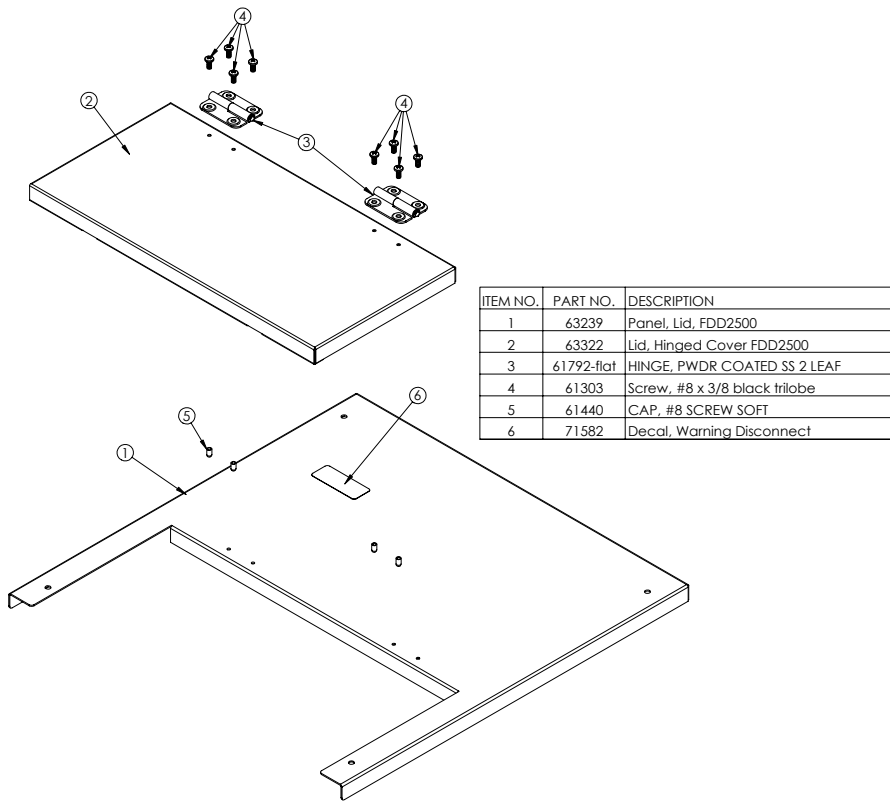

ITEM NO.	PART NO.	DESCRIPTION
1	63239	Panel, Lid, FDD2500
2	63322	Lid, Hinged Cover FDD2500
3	61792-flat	HINGE, PWDR COATED SS 2 LEAF
4	61303	Screw, #8 x 3/8 black trilobe
5	61440	CAP, #8 SCREW SOFT
6	71582	Decal, Warning Disconnect

## FDD2500 Splash Panel Assembly

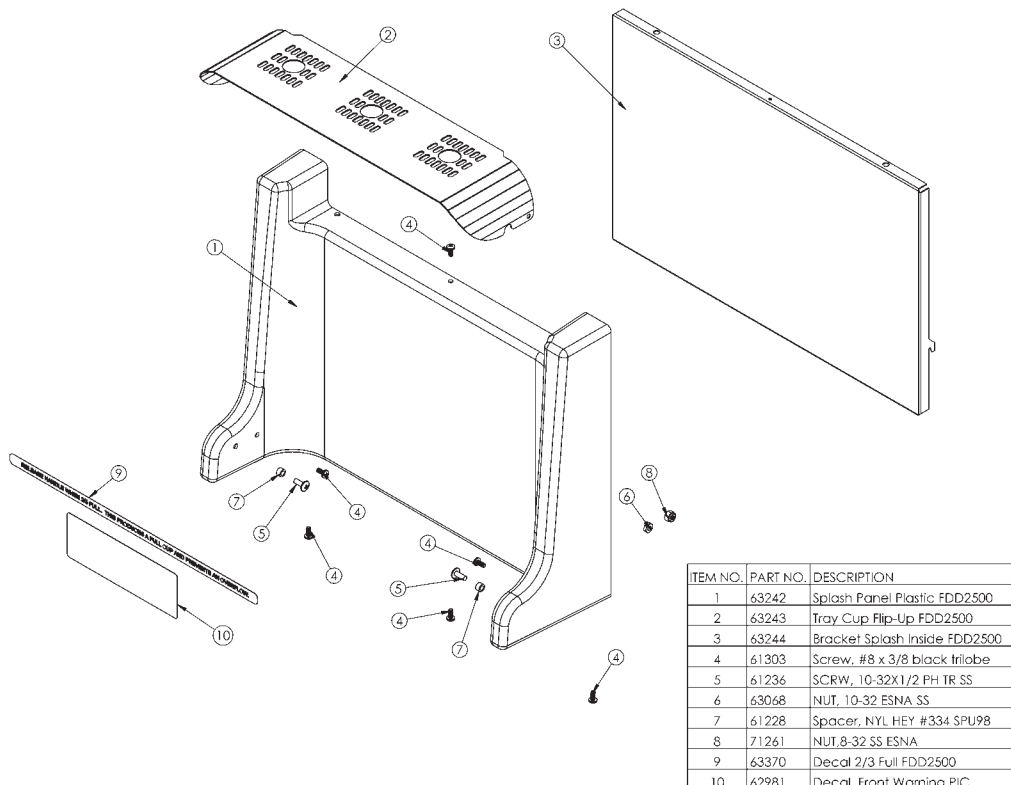

ITEM NO.	PART NO.	DESCRIPTION
1	63242	Splash Panel Plastic FDD2500
2	63243	Tray Cup Flip-Up FDD2500
3	63244	Bracket Splash Inside FDD2500
4	61303	Screw, #8 x 3/8 black trilobe
5	61236	SCRW, 10-32X1/2 PH TR SS
6	63068	NUT, 10-32 ESNA SS
7	61228	Spacer, NYL HEY #334 SPU98
8	71261	NUT, 8-32 SS ESNA
9	63370	Decal 2/3 Full FDD2500
10	62981	Decal, Front Warning PIC

# FDD2500 Hopper Shelf Assembly

ITEM NO.	PART NO.	DESCRIPTION	ITEM NO.	PART NO.	DESCRIPTION
1	63363	Bracket, Hopper Lower FDD	41	61303	Screw, #8 x 3/8 black trilobe
2	63362	Bracket, Hopper Upper FDD	42	65131	HEATER RING ASSEMBLY
3	63227	Hopper Asy., 406P FDD2500	43	63383	Sleeve Hopr. Nozzle FDD
4	63228	Faucet Coffee/Wciter FDD2500	44	63382	Fitting, Funnel Drop-in FDD
5	63318	Funnel Mixing FDD2500	45	63229	Bracket Spout Mtg FDD2500
6	63319	Fitting, Plenum Hose FDD2500	46	63393	Decal, "THIS SIDE UP"
7	63368	LT 1/6	47	07348-01	RIVET, POP MAX/G 1/8 X 1/8 SS
8	63368	RT 1/6	48	63376	Diffuser, Flow FDD2500
9	61618	Motor, 24VDC, Auger, 1.45 RPM	49	63371	Decal, Caution Surfaces are Hot
10	63321	Bracket Dump Valve Mtg FDD2500	50	71582	Decal, Warning Disconnect
11	62251	Valve Dump Unvented Deltal	51	71676	Clamp, 671-812, Nylon Hose
12	62271	FDD, Lt Fr	52	70425	TERM, 1/4MM INS, OD, 18-22 GA
13	62271	FDD, Md Fr	53	61264	Plug, 3/16" Hole
14	62271	FDD, Rt Fr			
15	61236	Hose Silicone 1/2" x 3/4" x 3.38"			
16	63235	Spacer, Nylon, 1/4IDx.312ODx.125L			
17	61228	Spacer, NYL HEY #334 SPU98			
18	63068	NUT, 10-32 ESNA, SS			
19	61157	PLUG, HOLE 1/2 HEYCO #3065			
20	100068	Strain Relief, Heyco, SR5M-3			
21	100205	Fan, 24VDC, 60mm			
22	63236	Cover Funnel FDD2500			
23	63237	Bracket Fan Louver FDD2500			
24	62218	Switch, Panel Mount Interlock			
25	63268	Pan Coffee Catcher FDD2500			
26	61440	CAP, #8 SCREW SOFT			
27	61847	Switch, Toggle-Spst			
28	61847-1	Nut, Switch, for 61847			
29	61242	Label, Flush On/Off			
30	61241	Label, Power			
31	61466	Switch, Toggle, 16 Amp Dpst			
32	61466-1	Nut, Switch, for 61466			
33	62286	Screw, 6-32X1.25 PH PN SS [A601018]			
34	61353	Screw, 8-32 X 1/4" PH PN 18-8 SS			
35	61250	Washer, #8 Split Lock			
36	63266	Sensor, Capacitive Carlo Gav			
37	63267	Bracket Cap Sensor Mtg FDD2500			
38	63317	Harness Hopr. Bkt FDD			
39	60145	6-32 x 3/4" SCREW, PH PN SS			
40	71084	Screw 8-32 X 1/2 PH HD			

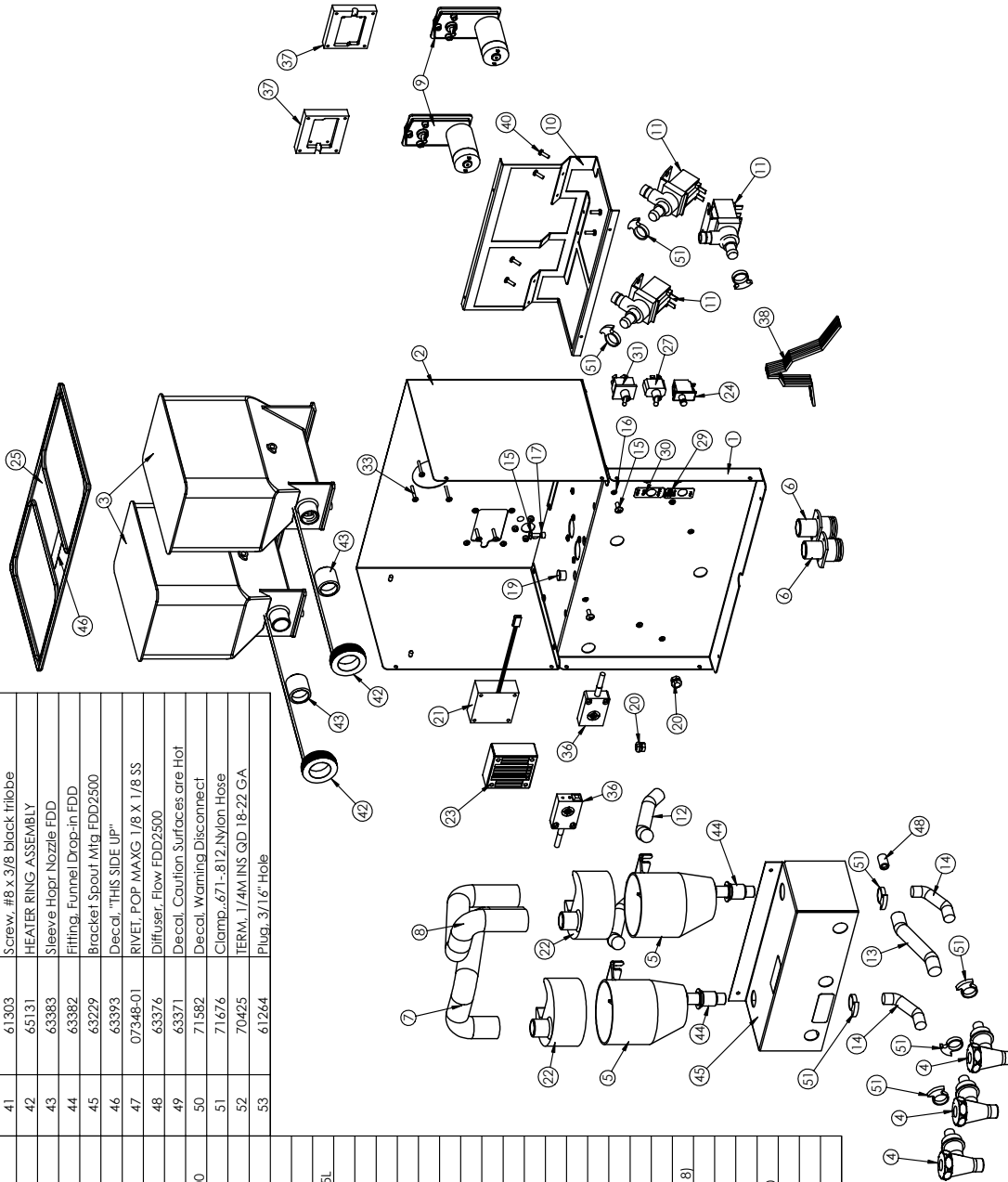

# FDD2500 Hopper Assembly

ITEM NO.	PART NO.	DESCRIPTION
1	60942	Hopper PIC1
2	60943	Lid Hopper 6 pound
3	60944	Pinwheel PIC1
4	61278	Auger, Spring, .406" Pitch
5	61230	DRIVESHAFT, AUGER SPRING
6	61246	BEARING, DRIVESHAFT
7	61225	LINK, AUGER DRIVE
8	61314	PALNUT, 5/8-11 UNC
9	61313	SPRING, PINWHEEL ARM
10	61437	SCREW, 6-32 KNURL
11	07301-04	WASHER A07301-04

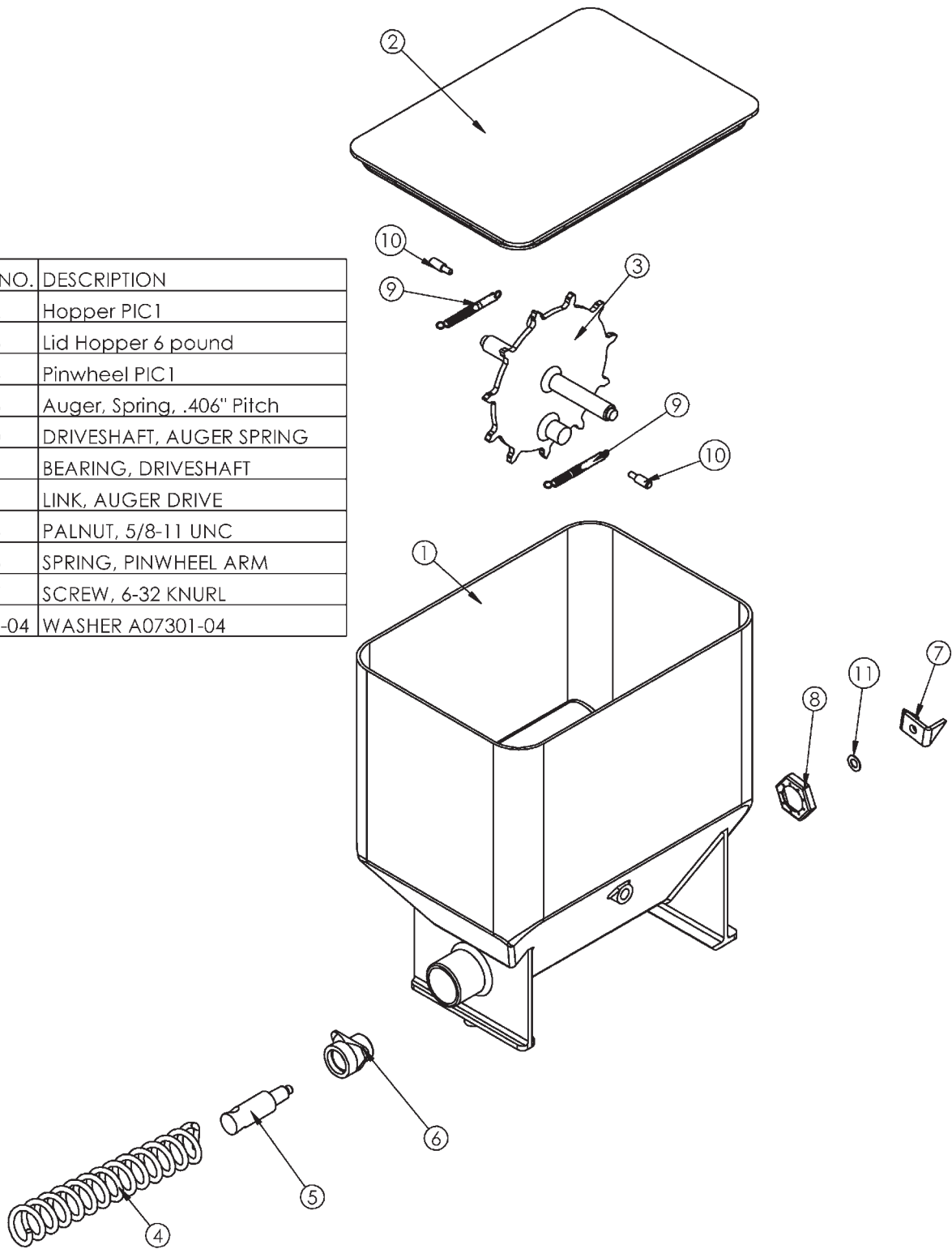

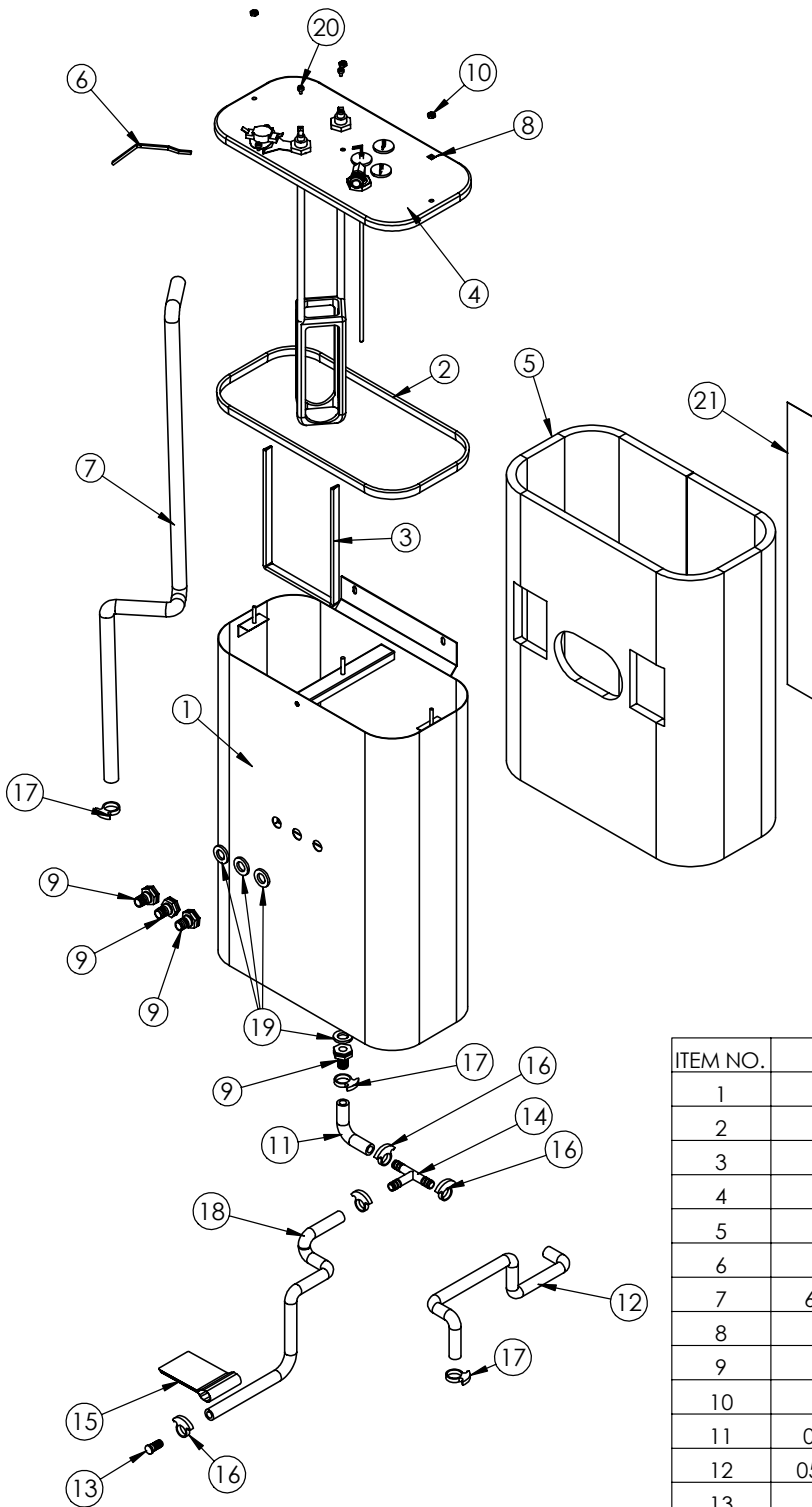

ITEM NO.	PART NO.	DESCRIPTION
1	63214	Tank Weldment FDD2500
2	63355 Tank	Gasket Tank 38"
3	63355 Baffle	Gasket Baffle 20"
4	63220	Tank Lid Asy FDD2500
5	63222	Insulation Tank FDD2500
6	63294	Harness Htr 1-Ph FDD2500
7	62271 FDD Vent	Tubing Silicone 1/2 x 3/4, 33"
8	70635	TERMINAL, 1/4-032 X 45DEG TAB
9	62269	Fitting, 1/2" Barb SS
10	63297	NUT, 10-24 ESNA SS
11	05826 FDD Short	Tubing Silicone 3/8 x 5/8 x 5"
12	05826 FDD IValve	Tubing Silicone 3/8 x 5/8 x 17"
13	61232	Plug, 3/8 Barb
14	61152	Tee, 7/16" Barbed
15	63448	Decal, Tank Drain 5+ Gal
16	07327	Clamp, Hose, 21/32ID, Heyco#2322
17	71676	Clamp, .671-.812, Nylon Hose
18	05826 FDD Drain	Tubing Silicone 3/8 x 5/8 x 25"
19	62282	Gasket, Bulkhead
20	61353	Screw, 8-32 X 1/4" PH PN 18-8 SS
21	60262, 18	TAPE, ALUM HI-TEMP 18,25"

# FDD2500 Tank Assembly – 3 Heater, 11.1kW

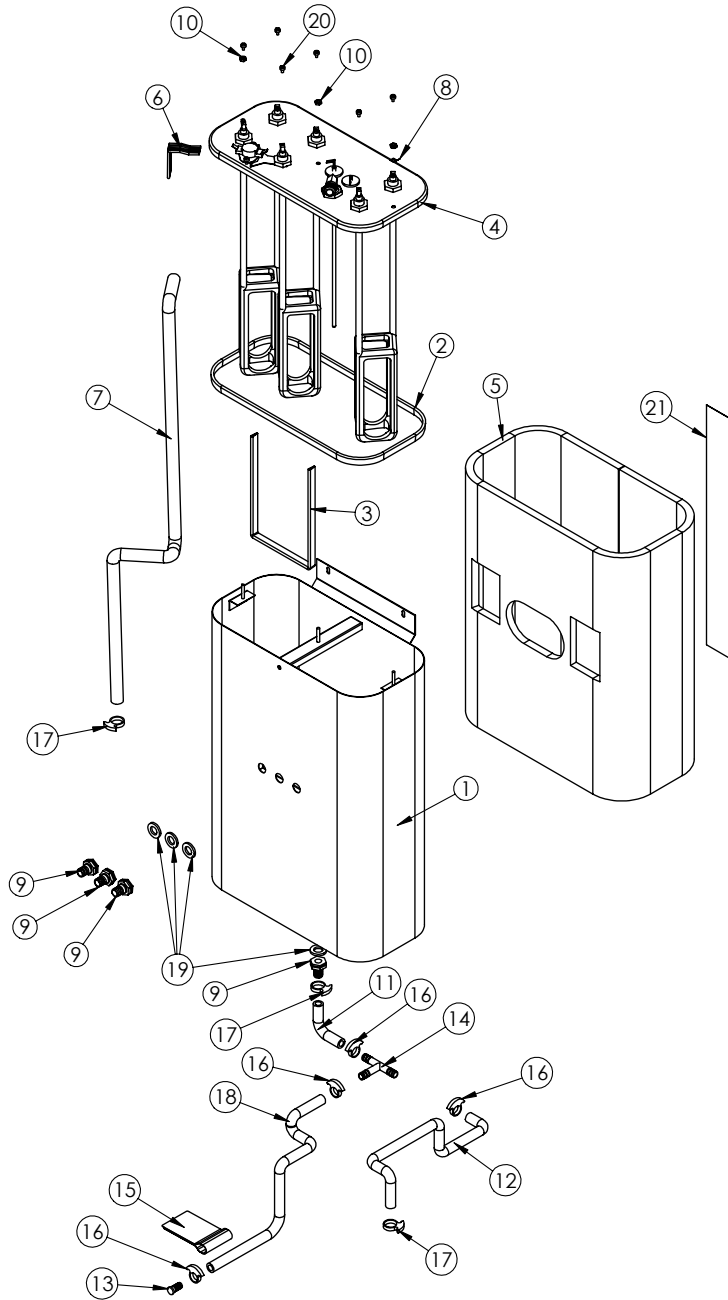

ITEM NO.	QTY.	PART NO.	DESCRIPTION
1	1	63214	Tank Weldment FDD2500
2	1	63355 Tank	Gasket Tank 38"
3	1	63355 Baffle	Gasket Baffle 20"
4	1	63261	Tank Lid Asy FDD2500
5	1	63222	Insulation Tank FDD2500
6	1	63295	Harness Heater 3-Ph FDD2500
7	1	62271 FDD Vent	Tubing Silicone 1/2 x 3/4, 33"
8	1	70635	TERMINAL, 1/4-032 X 45DEG TAB
9	4	62269	Fitting, 1/2" Barb SS
10	3	63297	NUT, 10-24 ESNA SS
11	1	05826 FDD Short	Tubing Silicone 3/8 x 5/8 x 5"
12	1	05826 FDD IValve	Tubing Silicone 3/8 x 5/8 x 17"
13	1	61232	Plug,3/8 Barb
14	1	61152	Tee, 7/16" Barbed
15	1	63448	Decal,Tank Drain 5+ Gal
16	4	07327	Clamp,Hose,21/32ID,Heyco#2322
17	3	71676	Clamp,.671-.812,Nylon Hose
18	1	05826 FDD Drain	Tubing Silicone 3/8 x 5/8 x 25"
19	4	62282	Gasket, Bulkhead
20	6	61353	Screw,8-32 X 1/4" PH PN 18-8 SS
21	1	60262,18	TAPE, ALUM HI-TEMP 18.25"

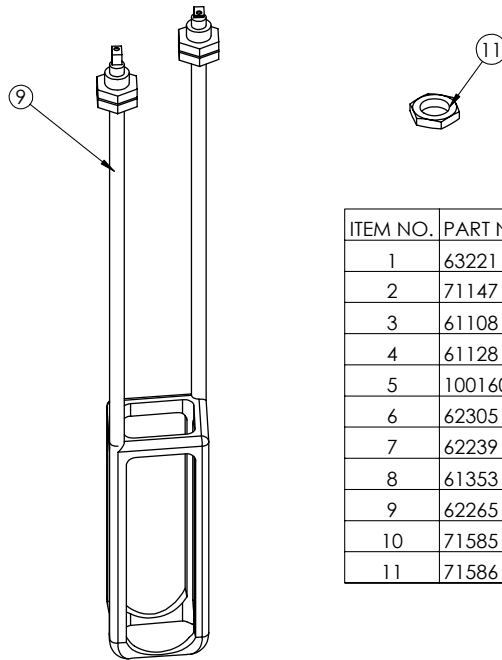
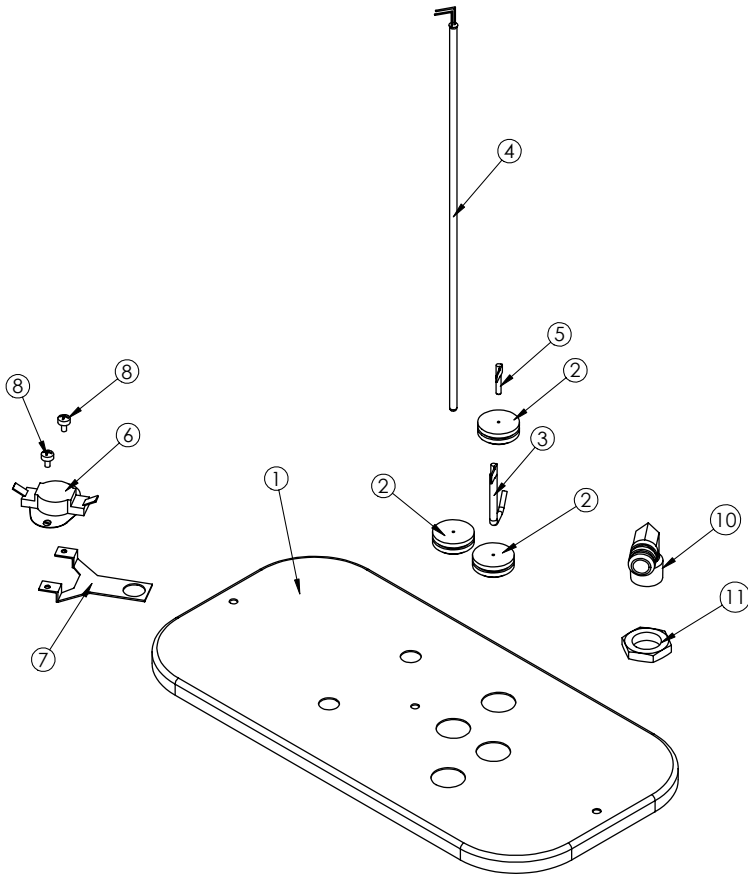

ITEM NO.	PART NO.	DESCRIPTION
1	63221	Lid Tank FDD2500
2	71147	GROMMET, SILICONE WHT
3	61108	PROBE, PIC
4	61128	Probe,Thermistor,12"
5	100160	Probe,Safety
6	62305	T-STAT, HI TEMP LIMIT
7	62239	BRKT, T-STAT CE MODEL
8	61353	Screw,8-32 X 1/4" PH PN 18-8 SS
9	62265	Element 240V 6.6kW
10	71585	Elbow,1/2mptx5/8barb 90 brass
11	71586	Nut,Lock,1/2fpt brass

# FDD2500 Tank Lid Assembly – 3 Heater

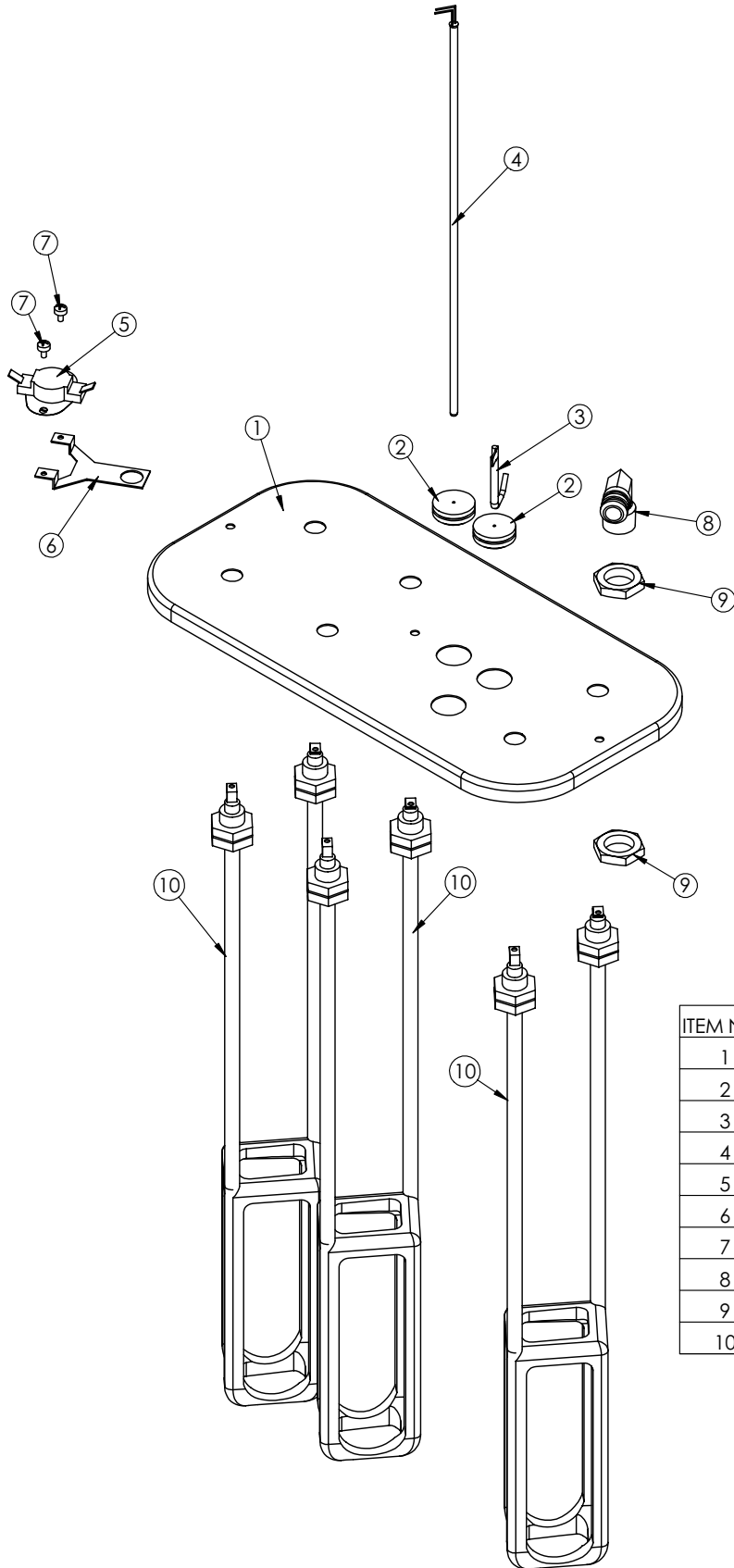

ITEM NO.	PART NO.	DESCRIPTION
1	63262	Lid Tank FDD2500
2	71147	GROMMET, SILICONE WHT
3	61108	PROBE, PIC
4	61128	Probe,Thermistor,12"
5	62305	T-STAT, HI TEMP LIMIT
6	62239	BRKT, T-STAT CE MODEL
7	61353	Screw,8-32 X 1/4" PH PN 18-8 SS
8	71585	Elbow,1/2mptx5/8barb 90 brass
9	71586	Nut,Lock,1/2fpt brass
10	62403	Element,240V, 3.7kW

# FDD2500 Control Bracket Assembly

ITEM NO.	PART NO.	DESCRIPTION
1	63324	Bracket Control Right FDD2500
2	63345	Valve Inlet 120V Brass
3	100045	TRANSFORMER, 100VA CHASSIS MOUNT
4	63400	Controller FDD2500
5	61266	STANDOFF, RVRS EDGEMOUNT
6	63346	Fitting 1/2barb x 3/8nptm
7	63347	Fitting 3/8mfl x 3/8nptm
8	71620	Bushing, Hole Heyco 1.094" 2166
9	61303	Screw, #8 x 3/8 black trilobe
10	63293	Harness Right FDD2500 Control

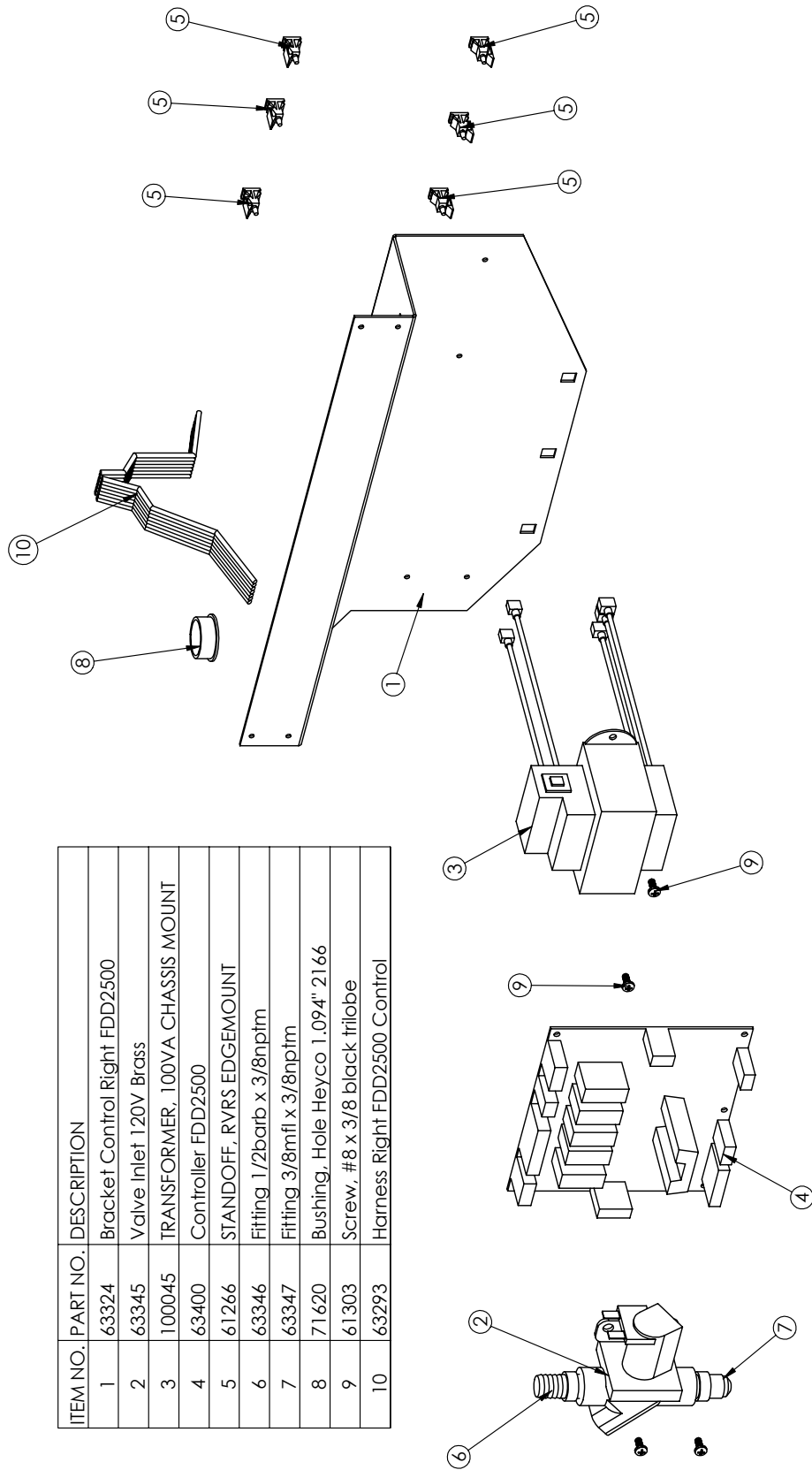

ITEM NO.	PART NO.	DESCRIPTION
1	63329	Bracket Control Left FDD2500
2	61131	Relay,12 vdc Coil
3	62262	Terminal Block 4-pole
4	62261	Contactur DPST 30A 120V
5	63373	Transformer StepD 200VA 200/230/460-120
6	63349	Harness Left Side FDD2500
7	62457	Harness Htr LCD, FDD 1-ph
8	62332	Fuseholder, 30A 600V pnl mt
9	63395	Fuse 2 Amp Time Delay
10	63396	Decal, 2 Amp Fuse
11	07921	Lug Ground
12	60394	Bushing,Snap-7/8"OD x 3/4"
13	10073	Label, Ground Symbol
14	62286	Screw 6-32x1.25 PH PN SS (A601018)
15	60746	10-24 x 5/16" SCREW, PH PN 18-8 SS
16	70426	TERM, 1/4F INS QD 18-22 GA
17	61303	Screw, #8 x 3/8 black trilobe
18	60758	WASHER, #10 LOCK EXT SS
19	61159-4	Seal, Closed Cell Foam 4"
20	63449	Decal, Step-Down Wiring

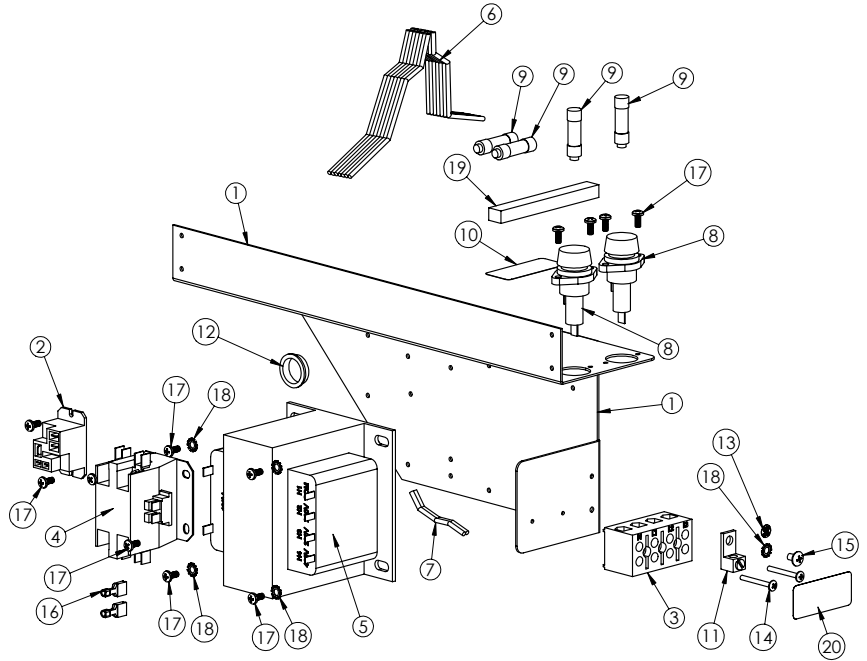

ITEM NO.	PART NO.	DESCRIPTION
1	63329	Bracket Control Left FDD2500
2	61131	Relay,12 vdc Coil
3	62262	Terminal Block 4-pole
4	61998	Contactur 4-Pole
5	63373	Transformer StepD 200VA 200/230/460-120
6	63349	Harness Left Side FDD2500
7	63350	Harness Term to Contact 3-Ph FDD
8	62332	Fuseholder, 30A 600V pnl mt
9	63395	Fuse 2 Amp Time Delay
10	63396	Decal, 2 Amp Fuse
11	07921	Lug Ground
12	60394	Bushing,Snap-7/8"OD x 3/4"
13	10073	Label, Ground Symbol
14	62286	Screw 6-32x1.25 PH PN SS (A601018)
15	60746	10-24 x 5/16" SCREW, PH PN 18-8 SS
16	70426	TERM, 1/4F INS QD 18-22 GA
17	61303	Screw, #8 x 3/8 black trilobe
18	60758	WASHER, #10 LOCK EXT SS
19	61159-4	Seal, Closed Cell Foam 4"
20	63449	Decal, Step-Down Wiring

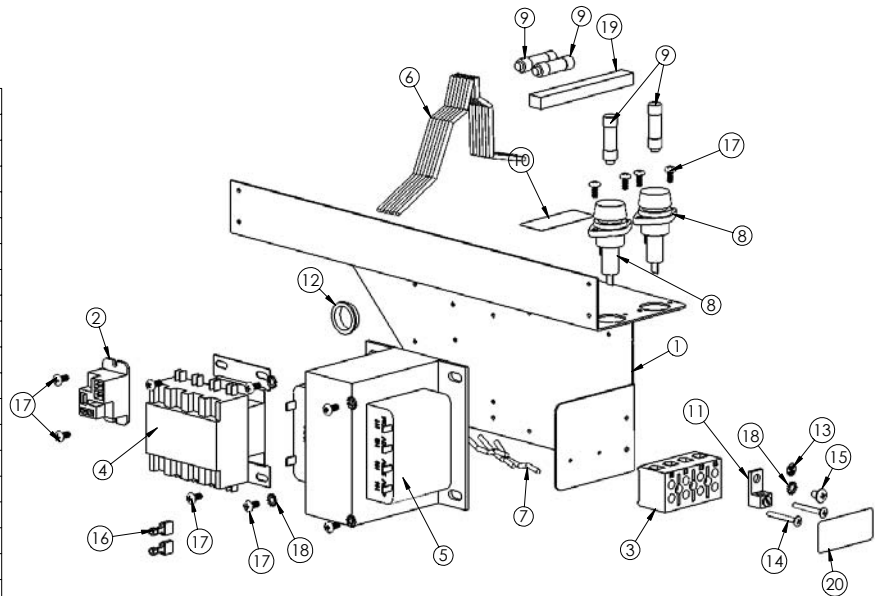

# FDD2500 Switch Assembly

Item No.	Part No.	Description
1	63285	Plate, Switch FDD2500
2	62260	Bezel, pull switch (A1101-020)
3	62266	Handle, Pull Switch - Coffee
	62267	Handle, Pull Switch - Hot Water
	62268	Handle, Pull Switch - Decaf
4	62281	Spring, Pull Switch A522120
5	61887	Switch, Snap Action Micro
6	61883	Bracket, Pull Switch Activation
7	63385	Rod, Pull Switch Modified A1101-019
8	62270	Pin, Pull Switch A551-015
9	71127	Screw 4-40 x 5/8 PH HD SS
10	71128	Nut, 4-40 SS Hex
11	71261	Nut, 8-32 SS ESNA
12	63447	Plate Striker

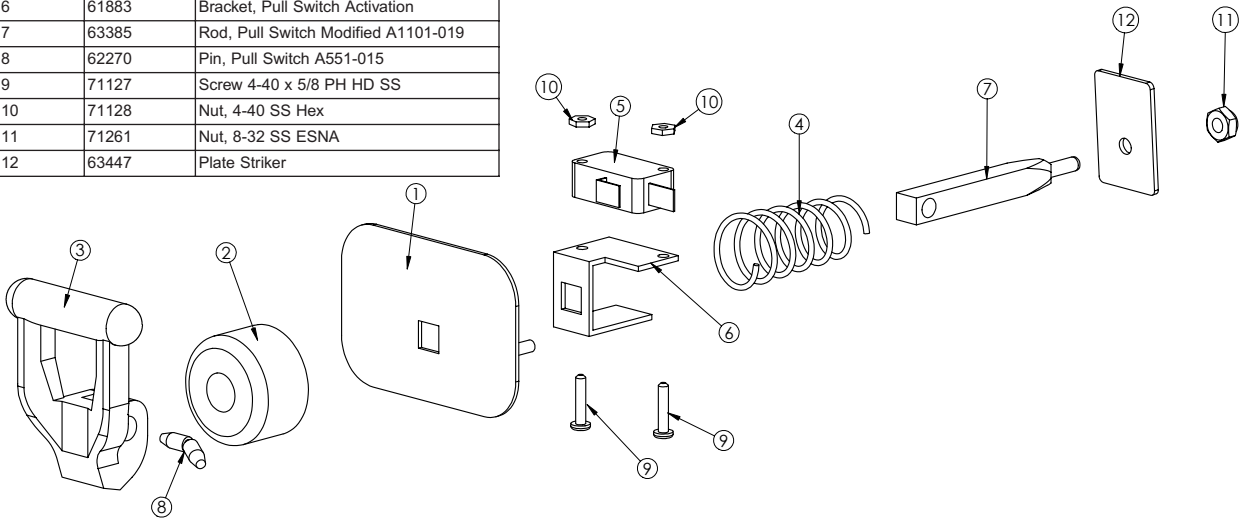

# FDD2500 Sight Gauge Assembly

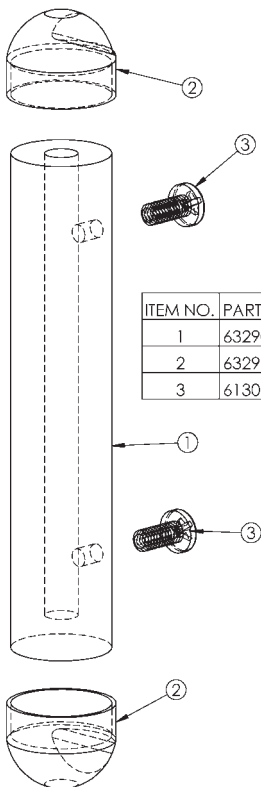

ITEM NO.	PART NO.	DESCRIPTION
1	63290	Tube Sight Gage FDD2500
2	63291	Cap Sight Gage
3	61303	Screw, #8 x 3/8 black trilobe

# FDD2500 Touchpad Assembly

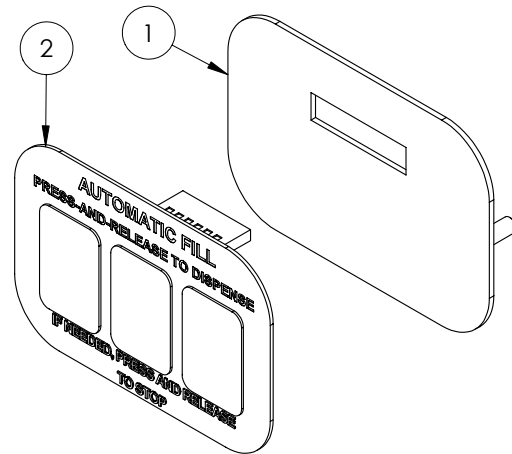

ITEM NO.	PART NO.	DESCRIPTION
1	63437	Plate, Switch FDD 3-Portion
2	63436	Touchpad 3-Port FDD2500

## FDD2500 Blower Assembly

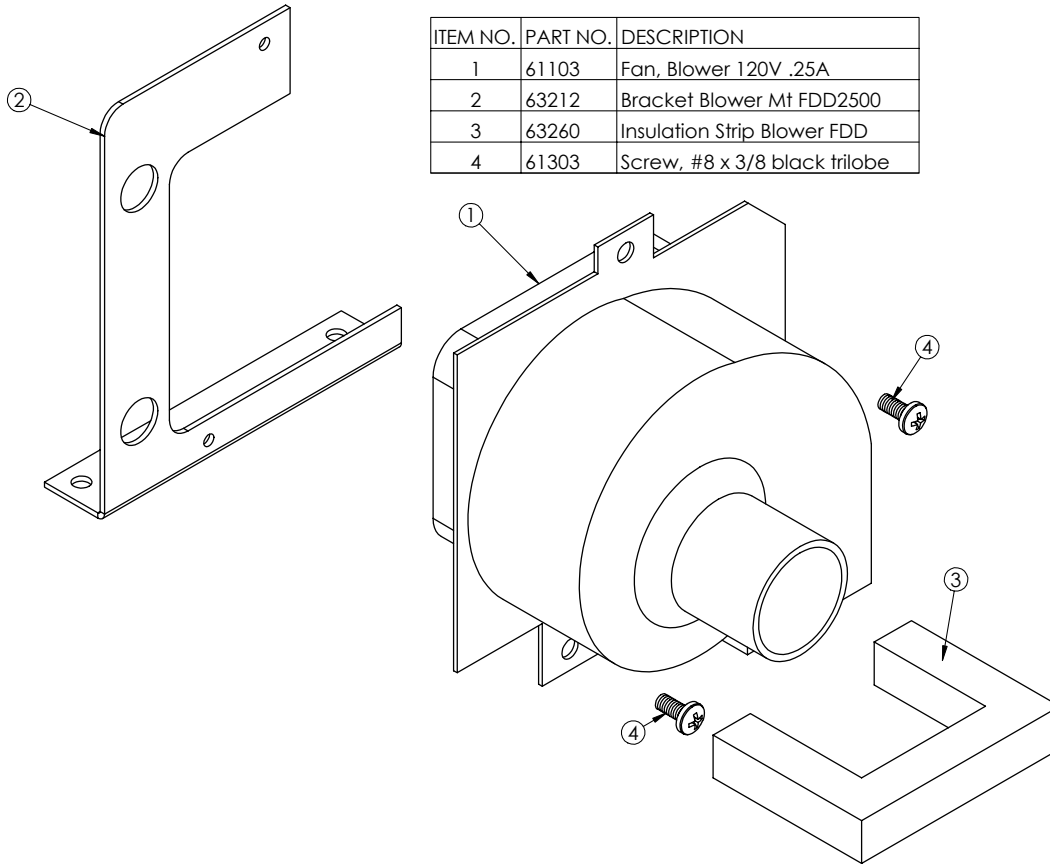

ITEM NO.	PART NO.	DESCRIPTION
1	61103	Fan, Blower 120V .25A
2	63212	Bracket Blower Mt FDD2500
3	63260	Insulation Strip Blower FDD
4	61303	Screw, #8 x 3/8 black trilobe

## FDD2500 Hose Adapter Assembly #63402 (Optional)

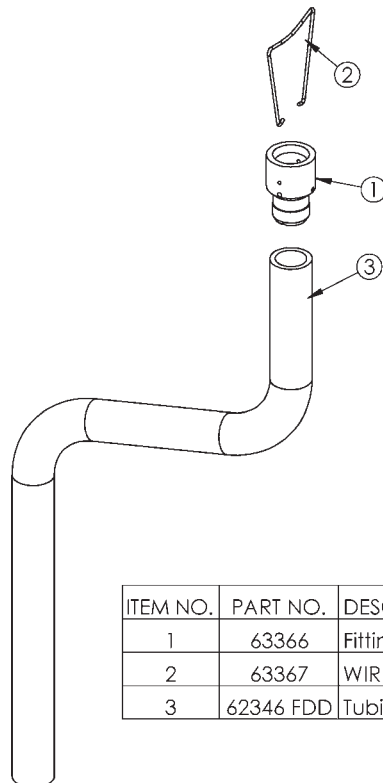

ITEM NO.	PART NO.	DESCRIPTION
1	63366	Fitting, Hose Adapt FDD2500
2	63367	WIRE CLIP HOSE ADAPTER
3	62346 FDD	Tubing 3/4 x 1 x 36" Silicone

# FDD2500 Wiring Schematic

for all models

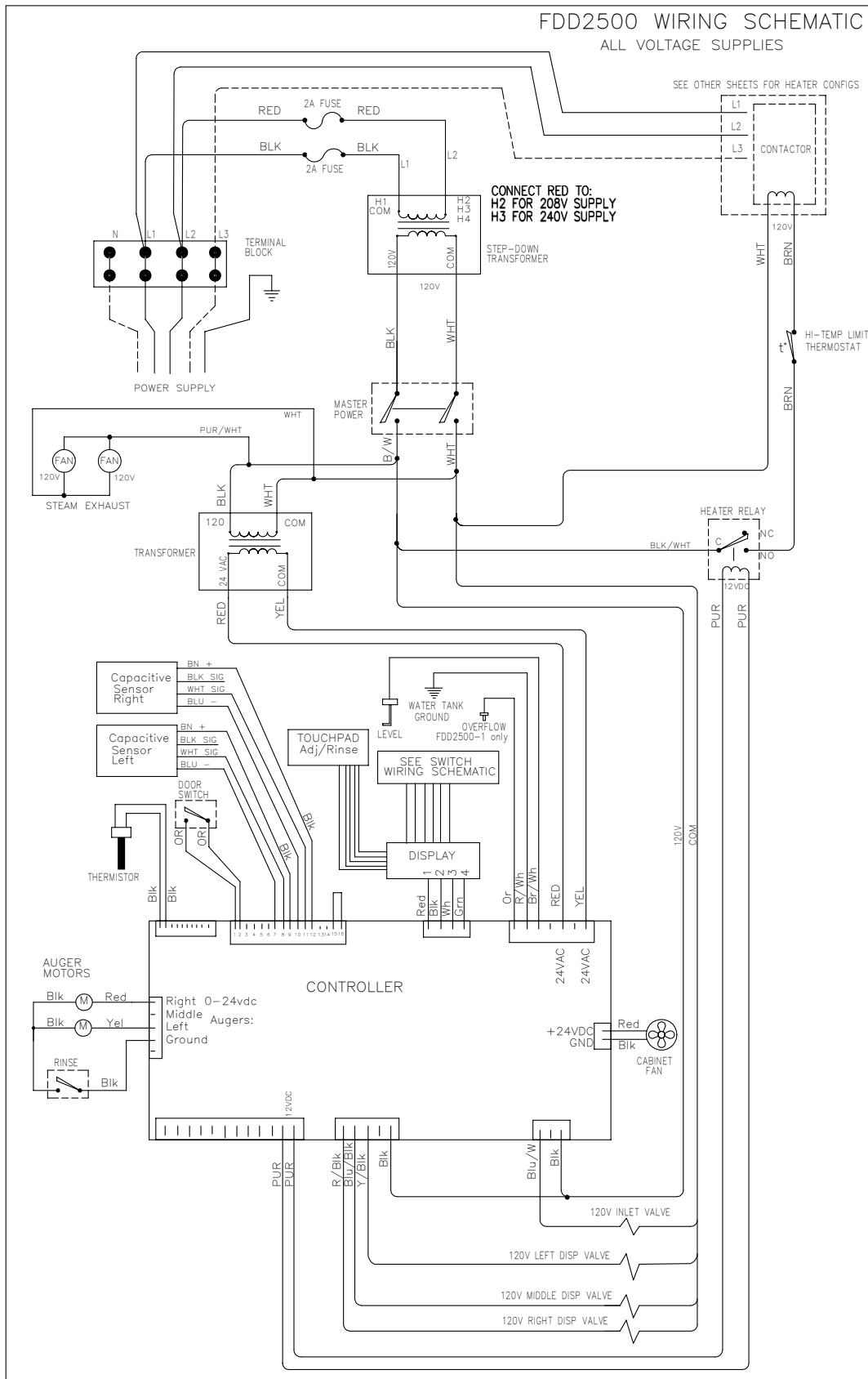

# 1 Heater, 1 Phase, 60 Hz, 240/208 VAC Configuration

for models FDD2500-1-M-B  
FDD2500-1-3A-B

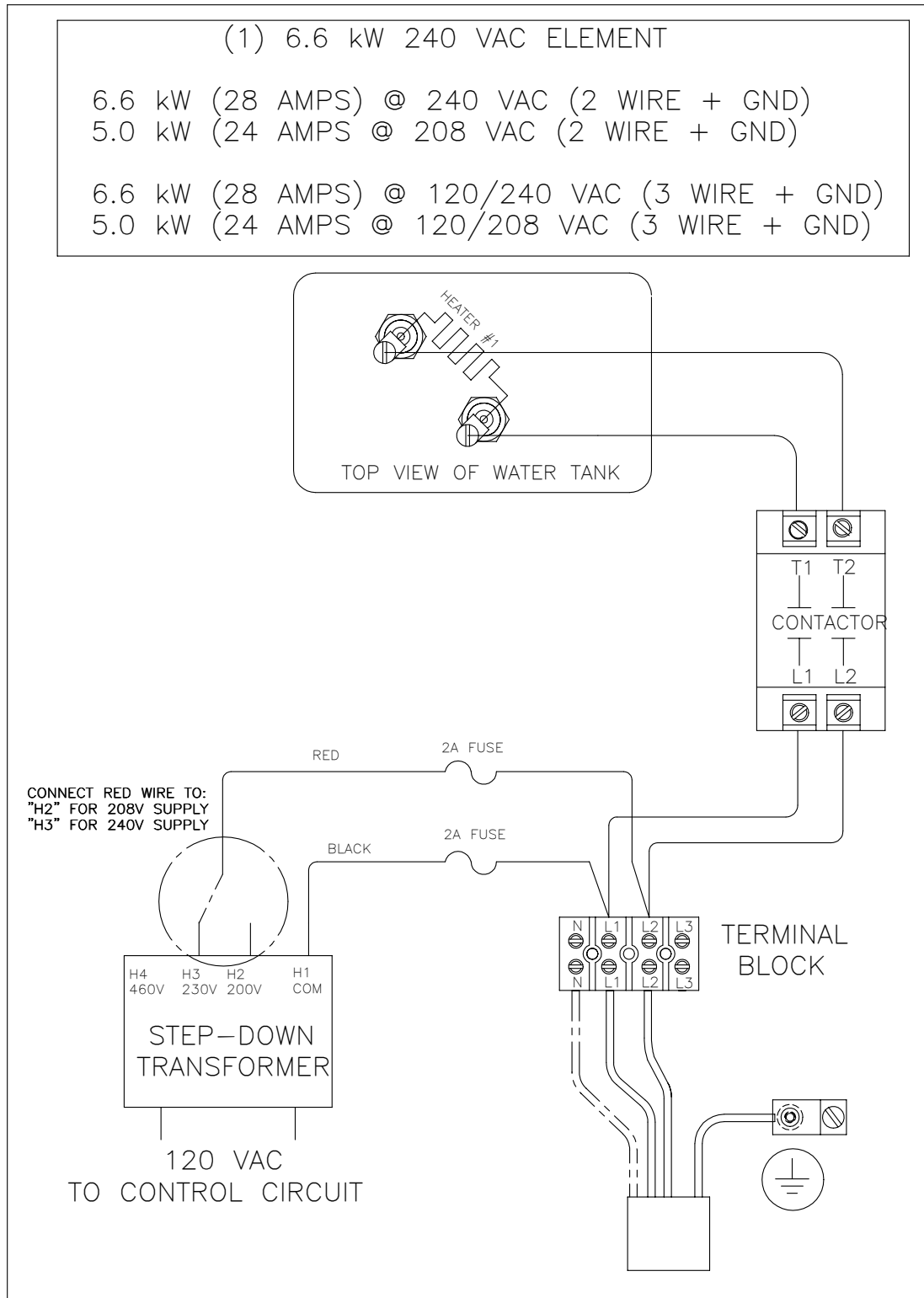

# Three Heater Option Configuration Hookup Diagram

for models FDD2500-3-M-B  
FDD2500-3-3A-B

## FDD2500-3 3-HEATER WIRING HOOK-UP

NOTE: MACHINE IS EQUIPPED WITH (3) 3.7kW 240 VAC ELEMENTS WHICH CAN BE CONFIGURED TO ACHIEVE VARIOUS WATTAGE OUTPUTS PER THE CHART BELOW DEPENDING ON POWER SOURCE AVAILABLE.

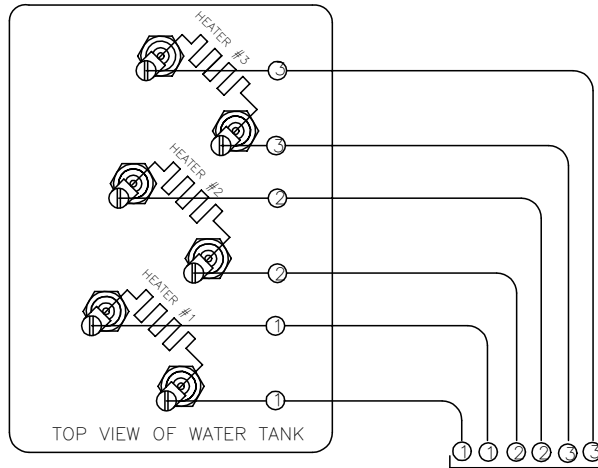

#10 AWG BLACK HEATER WIRES ARE CONNECTED TO CONTACTOR CONNECTIONS "T1,T2,T3,T4" PER THE CHART BELOW TO ACHIEVE THE SERIAL PLATE VOLTAGE AND WATTAGE CONFIGURATION

**CONNECT RED WIRE TO:  
"H2" FOR 208V SUPPLY  
"H3" FOR 240V SUPPLY**

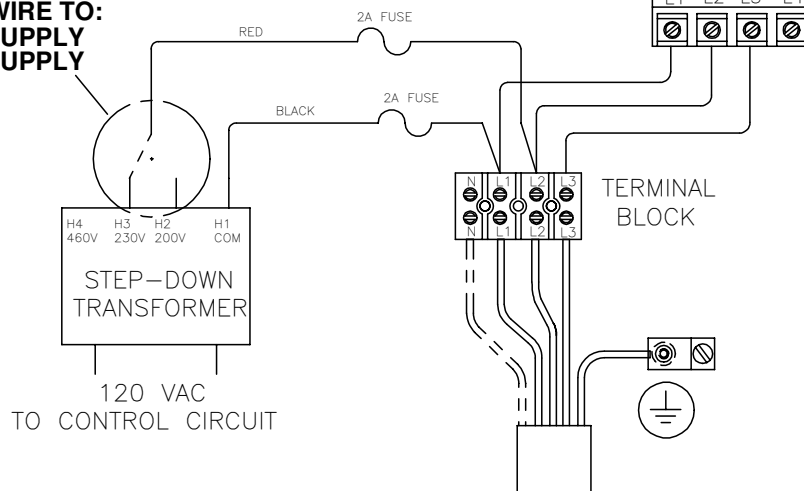

# OF ELEMENTS UTILIZED	VOLTAGE	WATTS	AMPS	CONNECT NUMBERED HEATER WIRES TO CONTACTOR TERMINALS PER CHART BELOW			
				T1	T2	T3	T4
SINGLE PHASE							
0.5	208	1390	6.7	1	2	1,2	3,3
1	208	2780	13.4	1	1	2,2	3,3
1.5	208	4140	19.9	1,2	1,3	2,3	-
2	208	5560	26.8	1,2	1,2	3,3	-
0.5	240	1850	7.7	1	2	1,2	3,3
1	240	3700	15.5	1	1	2,2	3,3
1.5	240	5550	23	1,2	1,3	2,3	-
2	240	7400	30.9	1,2	1,2	3,3	-
THREE PHASE (DELTA CONFIGURATION)							
3	208	8340	23.2	1,2	1,3	2,3	-
3	240	11100	26.8	1,2	1,3	2,3	-



# Wiring Schematic within Door

for models FDD2500-1-3A-B  
FDD2500-3-3A-B

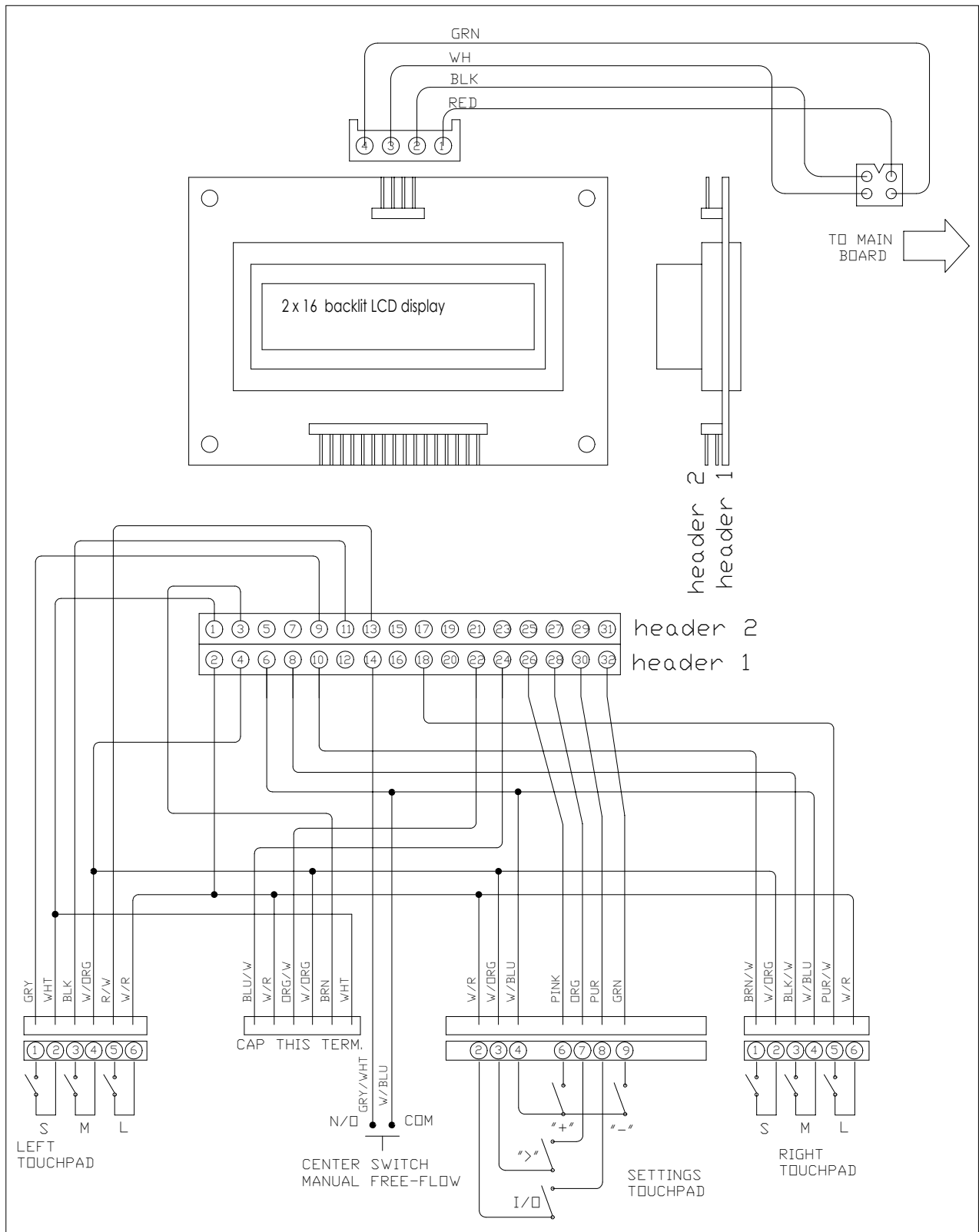







**GRINDMASTER™**  
CORPORATION

---

Grindmaster® Coffee Grinders and Brewers • Espresso® Espresso Machines • Crathco® Hot Beverage Dispensers  
Crathco® Cold and Frozen Beverage Dispensers • American Metal Ware® Coffee and Tea Systems  
Tel (502) 425-4776 • Fax (502) 425-4664 • 1-800-695-4500  
P.O. Box 35020 • Louisville, KY 40232 • USA  
[www.grindmaster.com](http://www.grindmaster.com) • email: [info@grindmaster.com](mailto:info@grindmaster.com)